



产品手册 2024
Product Catalog 2024



广芯电子技术(上海)股份有限公司
Broadchip Technology Group Co., Ltd.



BROADCHIP

COMPANY INTRODUCTION 公司介绍

广芯电子技术(上海)股份有限公司是由海外高层次人才戴忠伟先生领导的创业团队于2007年底在上海创立，公司被认定为高新技术企业、上海市科技小巨人培育企业，并获得上海市“专精特新”企业称号、工信部专精特新“小巨人”企业称号。

广芯电子专注于高性能的模拟和混合信号集成电路芯片产品的设计、研发和销售，其产品广泛应用于手机、平板、可穿戴设备、安防、网通、智能家居、家电等通用的消费电子产品以及通信、仪器仪表、工业控制等领域。

公司自成立以来，成功开发出十余系列，数百款型号产品，凭借产品的技术优势、创新功能、优异的性价比，以及公司良好的服务，广芯电子赢得了众多品牌客户的一致认可和信任。

广芯电子一贯注重产品的技术创新和产品的品质控制及重视客户需求，研发产品均有自主知识产权，目前公司已获发明专利、集成电路布图设计登记授权等一类知识产权五十多项。凭借在集成电路芯片领域十多年的产品研发经验积累和核心技术优势，广芯电子一直给客户提供稳定、可靠、高性价比的创新产品，同时我们为客户提供优质的技术服务和技术支持，广芯电子立志成为中国模拟集成电路芯片行业的领军企业。

使命：为客户提供最优质的模拟集成电路芯片产品和服务

愿景：中国模拟集成电路芯片设计的领军企业

企业价值观：

客户第一：满意度和认可度

员工第二：自豪感和幸福感

股东第三：投资回报率

企业行为准则： 踏踏实实做事 实实在在做人

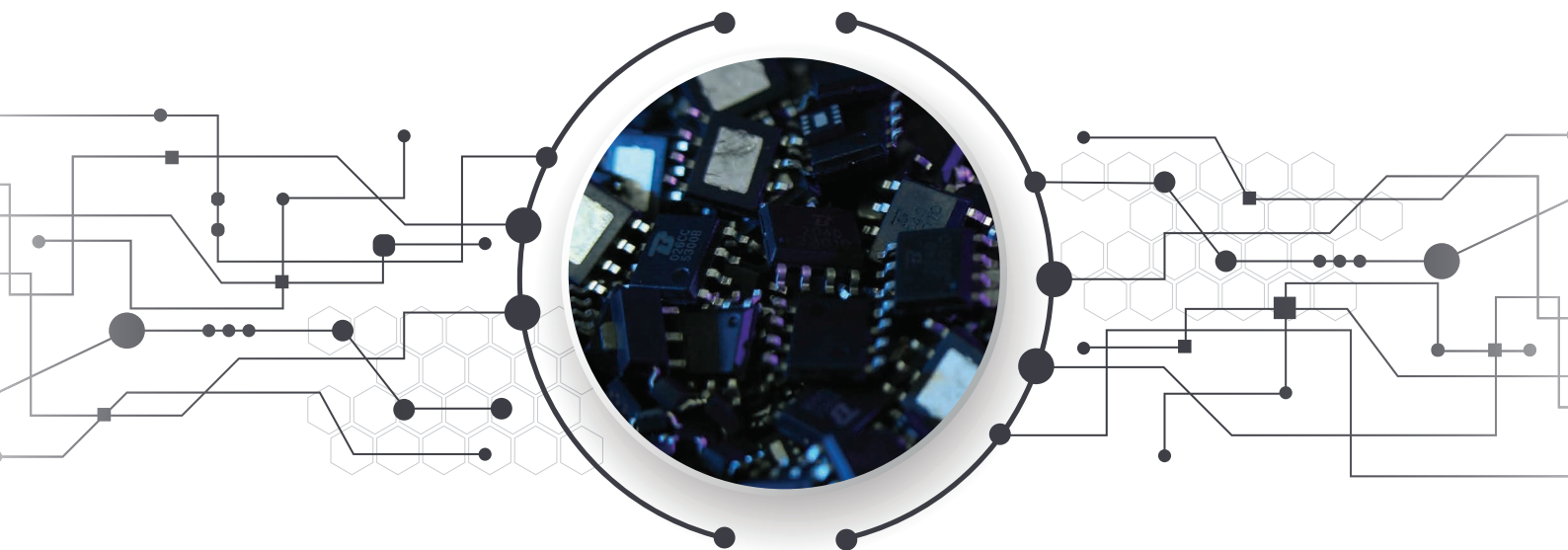

THE CERTIFICATION 资质证书



ABOUT BROADCHIP

认识广芯

· 2007年12月公司成立

· 多个项目被认定为上海市高新技术成果转化项目

· 通过高新技术企业认定

· 公司在全国中小企业股份转让系统成功挂牌

股票简称：广芯电子

股票代码：871366

· MIPI开关系列产品获得由ASPENCORE颁发的2019年度“中国IC设计成就奖-年度最佳放大器/数据转换器”奖项

· 完成新三板挂牌后第一轮融资3296.30万元

· 荣获上海市“专精特新”企业称号

· 荣获工信部专精特新“小巨人”企业称号

· 进入全国中小企业转让系统创新层

2007

· 获评《电子工程专辑》颁发“2010年中国IC设计公司成就奖 - 十大杰出技术支持中国IC设计公司”奖项

· 戴忠伟先生入选“国家特聘专家”和“海外高层次人才”

· 通过ISO质量管理体系认证、ISO环境管理体系认证

2016

2017

2019

· MIPI开关系列产品获得由ASPENCORE颁发的2020年度“中国IC设计成就奖-年度最佳放大器/数据转换器”奖项

2020

2021

· 年度总交付芯片数量超5.5亿颗

2022

· 年度总交付芯片数量超7亿颗

· 完成新三板挂牌后第三轮融资8000万元

2023

· 搬迁至上海闵行区莘庄镇维璟中心H幢17层新场地

Broadchip Product Line
产品线

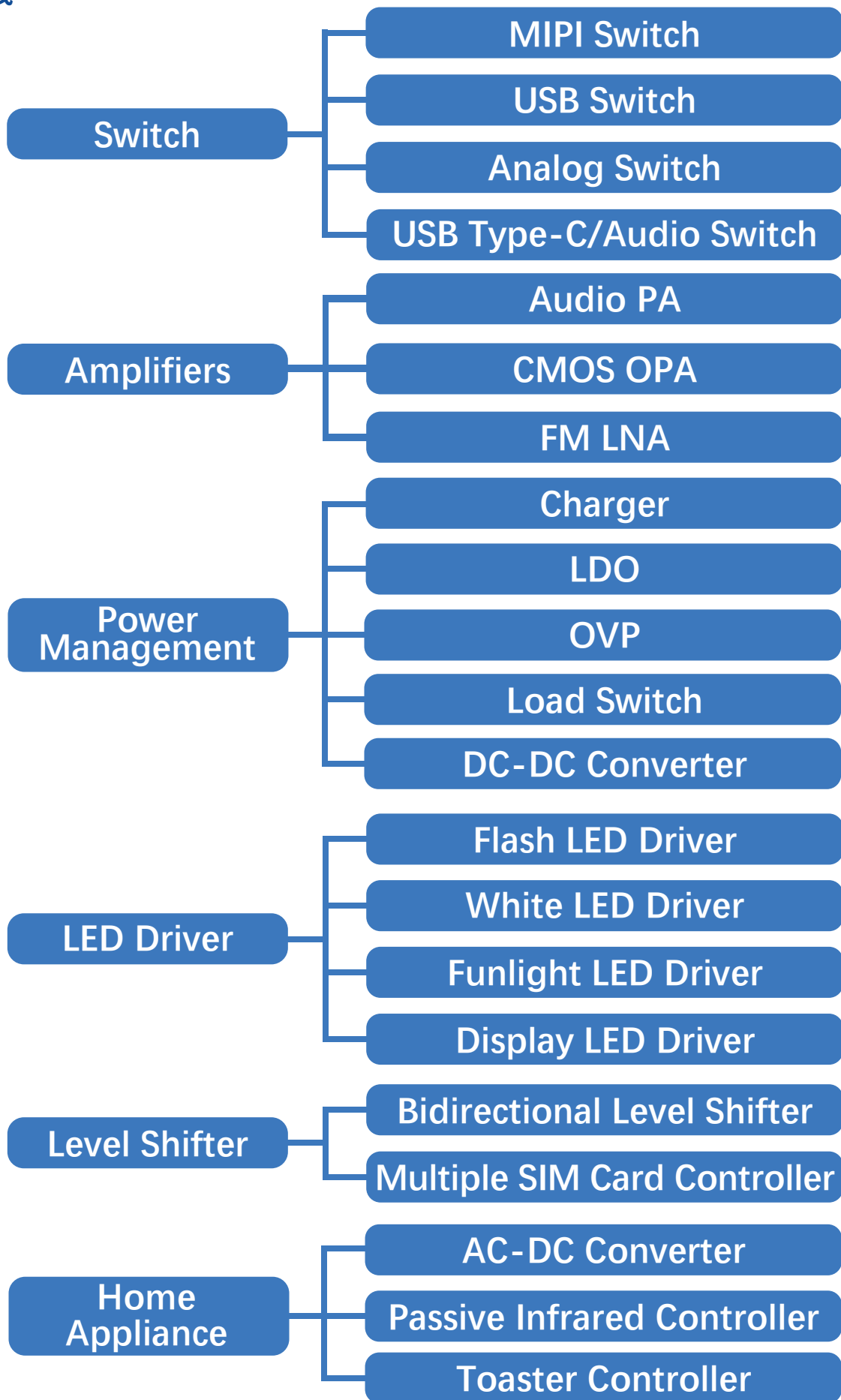

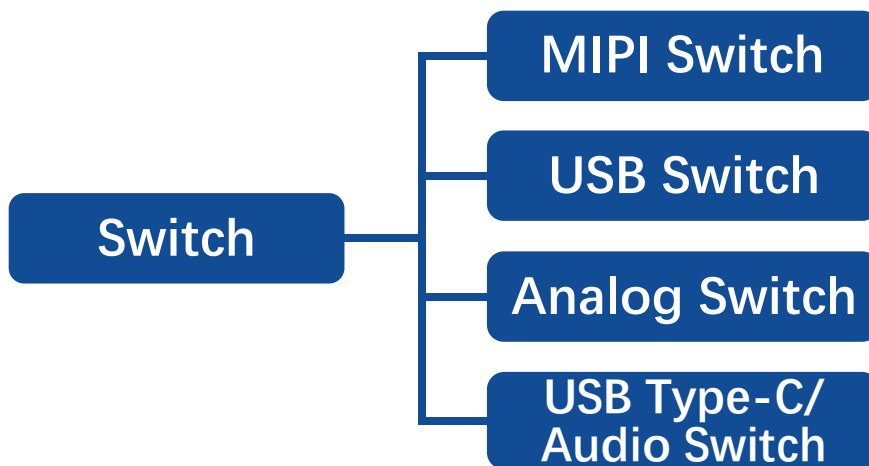

PART No.	Description	V _{IN} (V)	Channels	DDR Bandwidth (Gbps/L)	R _{ON} (Ω)	C _{ON} (pF)	Package	Cross Reference
BCT634	2:1 MIPI D-PHY,C-PHY (2.5Gbps) 4-Data Lane Switch	1.65-4.5	4DATA 1CLK	2.5	6	5.2	WLCSP-36L (0.35Pitch)	FSA634
BCT636	2:1 MIPI D-PHY,C-PHY (4.5Gbps) 4-Data Lane Switch	1.5-5.0	4DATA 1CLK	4.5	6.5	1.5	WLCSP-36L (0.35Pitch)	FSA634
BCT642A	2:1 MIPI D-PHY (2.5Gbps) 2-Data Lane Switch	1.65-4.5	2DATA 1CLK	2.5	6	5	QFN3.4x2.5-24L	FSA642
BCT644	2:1 MIPI D-PHY (2.5Gbps) 4-Data Lane Switch	1.65-4.5	4DATA 1CLK	2.5	7.7	5.2	WLCSP-36L	FSA644
BCT644C	2:1 MIPI D-PHY,C-PHY (2.5Gbps) 4-Data Lane Switch	1.65-4.5	4DATA 1CLK	2.5	6	5	FO-36L	FSA644
BCT646	2:1 MIPI D-PHY,C-PHY (4.5Gbps) 4-Data Lane Switch	1.5-5.0	4DATA 1CLK	4.5	6.5	1.5	WLCSP-36L	FSA646 TS5MP646 PI3WVR646
BCT646C	2:1 MIPI D-PHY,C-PHY (4.5Gbps) 4-Data Lane Switch	1.5-5.0	4DATA 1CLK	4.5	6.5	1.5	FO-36L	FSA646 TS5MP646 PI3WVR646
BCT660	2:1 MIPI C-PHY (5.7Gbps) 1-Data Lane Switch	1.5-5.0	1DATA	5.7	5.4	0.8	QFN2.8x2.0-18L	FSA660

WLCSP-36L

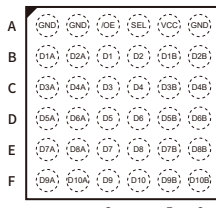

BCT634/BCT636

QFN3.4x2.5-24L

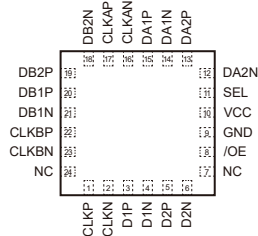

BCT642A

WLCSP-36L
FO-36L

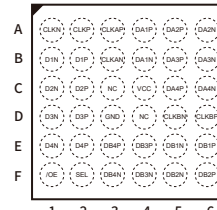

BCT644/BCT644C

WLCSP-36L
FO-36L

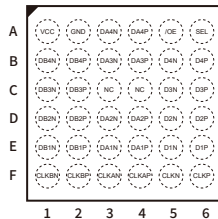

BCT646/BCT646C

QFN2.8x2.0-18L

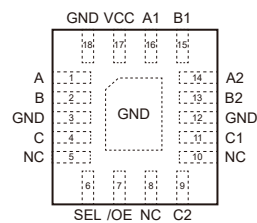

BCT660

PART No.	Description	Configuration	V _{CC} (V)	R _{ON} (Ω)	Cross Talk (dB)	-3dB Bandwidth (MHz)	Package	Cross Reference
BCT4221A	High-Speed DPDT Analog Switch	DPDT(X1)	2.3-5.5	2	-45	1800	QFN1.8x1.4-10L QFN2.0x1.5-10L	TS3USB221 NX3DV221
BCT4222A	High-Speed DPDT Analog Switch	DPDT(X1)	1.65-4.5	7	-30	700	WQFN1.8x1.4-10L	TS3USB30E FSUSB30 NLAS7222 PI3USB10LP-A
BCT4222C	High-Speed DPDT Analog Switch	DPDT(X1)	1.65-4.5	7	-30	700	MSOP10	TS3USB30E FUSB30MUX
BCT4227	High-Speed DPDT Analog Switch	DPDT(X1)	1.65-4.5	7	-54	720	MSOP10 QFN1.8x1.4-10L	FSUSB42UMX
BCT4228	High-Speed DPDT Analog Switch	DPDT(X1)	1.65-4.5	7	-54	720	MSOP10 QFN1.8x1.4-10L	FSUSB104
* BCT4000	High-Speed DPDT Analog Switch With OVP	DPDT(X1)	2.3-5.5	5.5	-90	1500	QFN1.8x1.4-10L QFN2.0x1.5-10L	PI3USB4000A DIO5000
BCT4340	USB3.1 Super Speed 10 Gbps Switch	QPDT(X1)	1.5-5.0	5.4	-44	10000	QFN2.8x2.0-18L	FUSB340
BCT4350	USB3.1 Super Speed 10 Gbps Switch	QPDT(X1)	1.5-5.0	5.4	-44	10000	TQFN4.5x2.5-20L	CBTL02043A PI3USB302 PI3PCIE3212

* Please Contact Our Sales Office For More Details

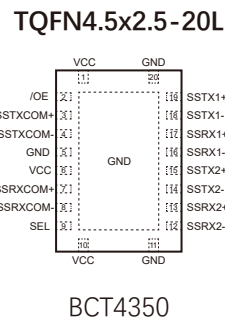
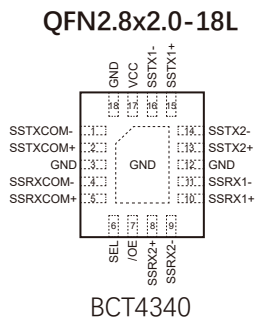
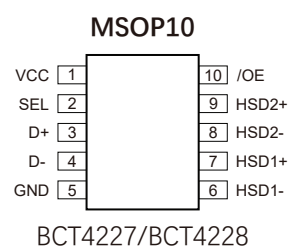
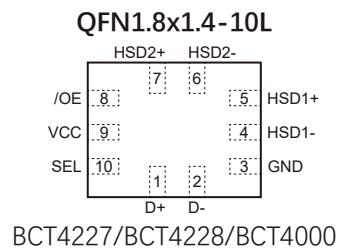
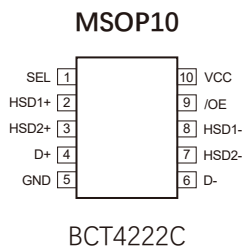
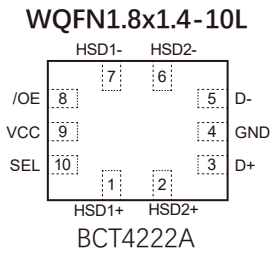
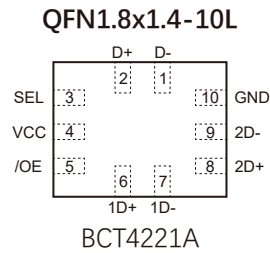
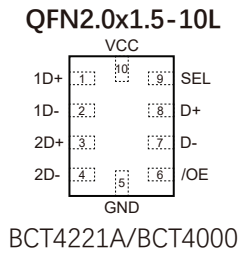

Analog Switch

PART No.	Description	Configuration	V _{CC} (V)	R _{ON} (Ω)	Cross Talk (dB)	-3dB Bandwidth (MHz)	Package	Cross Reference
BCT4157	Low-Voltage, Analog Switch	SPDT(X1)	1.65-5.5	2.8	-54	300	SC70-6L SOT23-6 DFN1x1-6L DFN1.1x0.9-6L	SN74LVC1G3157 TS5A3157/FSA3157/5157 NC7SBU3157/WAS3157 NLAS4157/PI5A3157 SGM3157/4157/RS2057 ET3157/BL1551/DIO3157
BCT4223	Low-Voltage, Analog Switch	SPDT(X2)	1.65-5.0	1.2	-103	100	QFN1.8x1.4-10L	TS3A5223 FSA2259UMX NLAS5223/PI3A223 SGM5223/SGM3718
BCT4699	Ultra Low ON-Resistance Low-Voltage, Analog Switch	DPDT(X2)	1.8-5.0	0.5	-86	100	TQFN3x3-16L UTQFN2.6x1.8-16L	TS3A44159 NLAS3699/PI3A412 SGM3699
BCT4899	Low-Voltage, Analog Switch	DPDT(X2)	1.8-5.5	5	-60	500	TQFN3x3-16L QFN2.5x2.5-16L UTQFN2.6x1.8-16L	FSA2466/MAX4699 NLAS3899B/PI3A3899 SGM44599
BCT4330	Low-Voltage, Analog Switch	QPDT(X1)	1.8-5.5	5	-60	500	SOP16 SSOP16 TSSOP16 QFN3x3-16L QFN3x3-20L	ADG774/774A/794 G3204 FSAL200 FSAV330/430 ADG784 FST3253/3257 PI3L110/PI3V312/PI5L200 SN74XX3257/STMAV340 SGM5018/330A TMUX1574/TS3A5018
BCT44600	Low-Voltage, Analog Switch	QPDT(X1)	1.8-5.5	5	-60	500	QFN3x3-16L	SGM44600
BCT44602	Low-Voltage, Analog Switch	QPDT(X1)	1.8-5.5	5	-60	500	QFN2.6x1.8-16L	SGM44602
BCT44603	Low-Voltage, Analog Switch	QPDT(X1)	1.8-5.5	5	-60	500	QFN2.6x1.8-16L	FSA2457 SGM44603

SC70-6L
SOT23-6

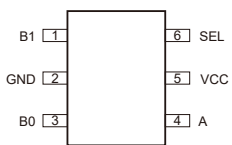

BCT4157

DFN1x1-6L
DFN1.1x0.9-6L

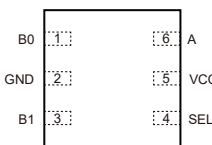

BCT4157

QFN1.8x1.4-10L

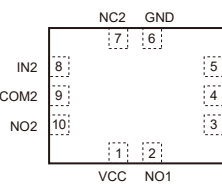

BCT4223

TQFN3x3-16L
QFN2.5x2.5-16L

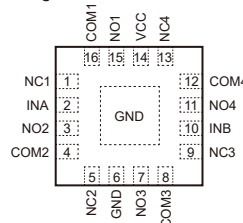

BCT4699/BCT4899

QFN2.6x1.8-16L
UTQFN2.6x1.8-16L

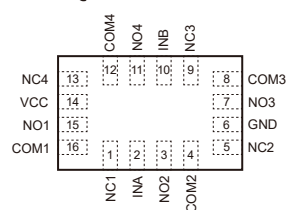

BCT4699/BCT4899

SOP16
SSOP16/TSSOP16

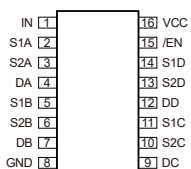

BCT4330

QFN3x3-16L

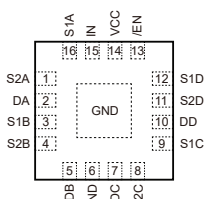

BCT4330

QFN3X3-20L

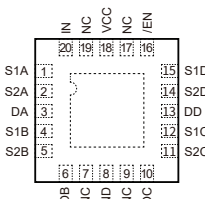

BCT4330

QFN3x3-16L

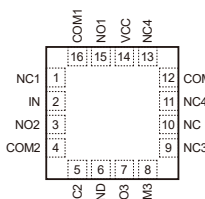

BCT44600

QFN2.6x1.8-16L

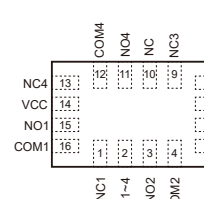

BCT44602

QFN2.6x1.8-16L

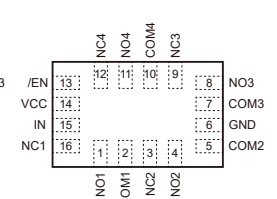

BCT44603

Analog Switch

PART No.	Description	Configuration	V _{CC} (V)	R _{ON} (Ω)	Cross Talk (dB)	-3dB Bandwidth (MHz)	Package	Cross Reference
BCT4567A	Low-Power, Dual SIM Card Analog Switch	QPDT(X1)	1.65-5.0	0.3	-76	260	TQFN3x3-16L UTQFN2.6x1.8-16L	FSA2567
* BCT4717	Dual-SPDT Analog Switch	SPDT(X2)	1.8-5.5	4	-99	300	FO-10L QFN1.8x1.4-10L	SGM4717
BCT48751	Low-Voltage, Analog Switch	SP8T(X1)	2.5-5.5	48		300	SOP16 SSOP16 TSSOP16 QFN3x3-16L	SN74HC4851 TMUX1308 SGM48751
BCT48752	Low-Voltage, Analog Switch	DPQT(X1)	2.5-5.5	48		300	SOP16 SSOP16 TSSOP16 QFN3x3-16L	SGM48752 SN74HC4052

* Please Contact Our Sales Office For More Details

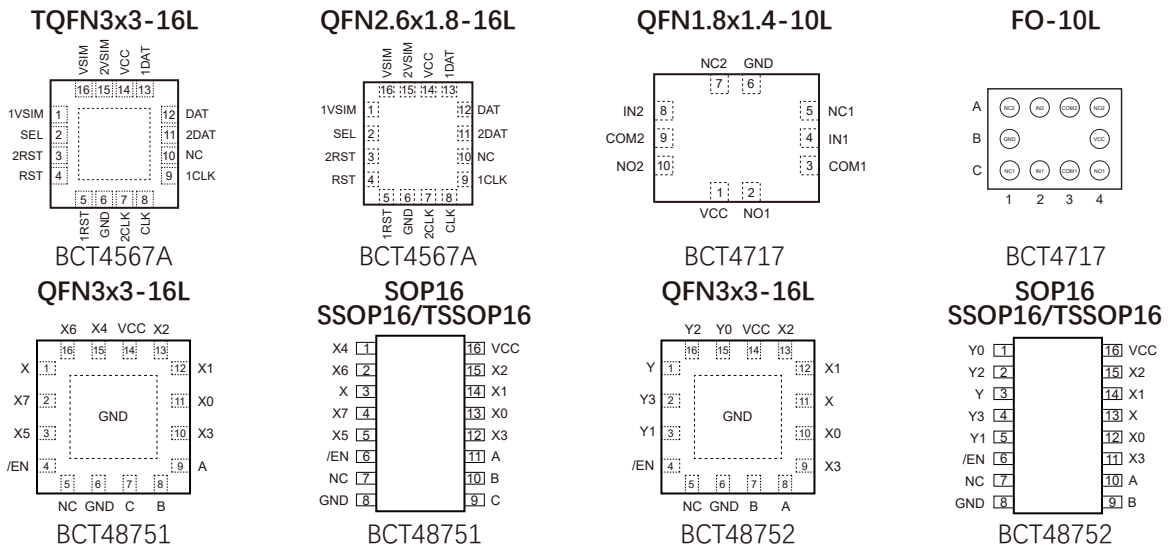

USB Type-C/Audio Switch

PART No.	Description	V _{CC} (V)	Audio-R _{ON} (Ω)	USB-R _{ON} (Ω)	Analog Signal Range (V)	-3dB Bandwidth (MHz)	Package	Cross Reference
BCT4480	USB Type-C Analog Audio Switch with Protection Function	2.7-5.5	1.0	3.0	0 to 20	950	WLCSP-25L	FSA4480
BCT4481	USB Type-C Analog Audio Switch with Protection Function	2.7-5.5	1.0	3.0	0 to 20	950	FO-25L	FSA4480
BCT4888	USB Type-C USB3.2/2.0 Analog Audio Switch with Audio Ground Detection	2.7-5.5	1.0	3.0	0 to 20	600	QFN9.0x3.5-42L	
BCT4321N	High-Speed and Audio Switches with Negative Signal Capability(-2V)	2.7-5.0	2.5	8.5	V _{CC} -6.5 to V _{CC} -2	720	QFN1.8x1.4-10L	FSA321

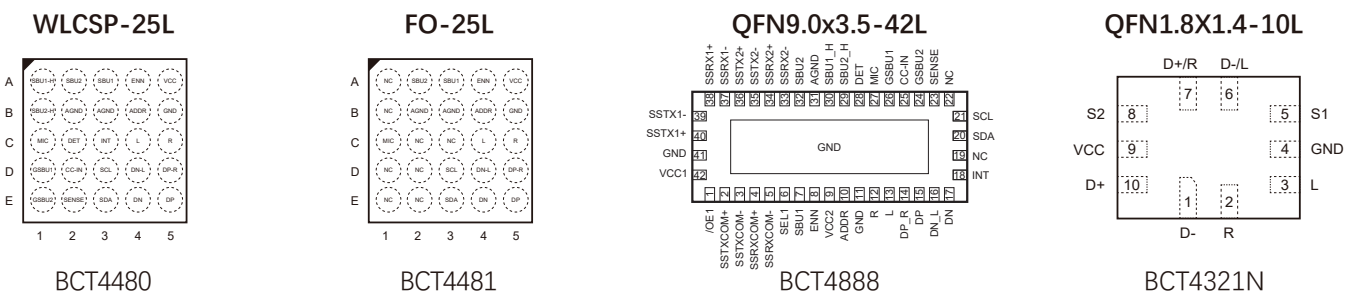

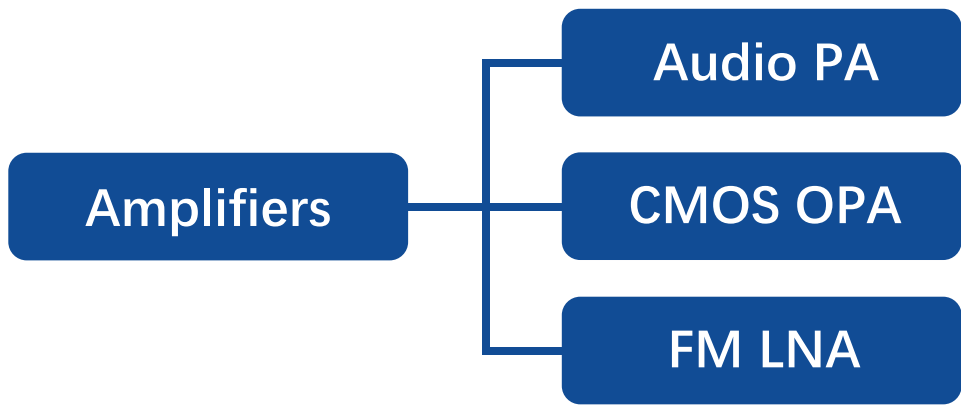

PART No.	Description	Class	Po- 8Ω (W)	V _{IN} (V)	THD+N (%)	I _{SHDN} (uA)	PSRR (dB)	Package	Cross Reference
BCT8002	Low-Cost, Mono 2.2W Audio Power Amplifier	AB	1.5	2.5-5.5	0.1	1	-64	SOP8	BD783XX/LY8898 IS31AP4991A/4996/APA3010 LM4871/4902 /4991 TPA301/321/701/721/741 SGM4871/TS4871/TS4890 NCS2111/SSM2211
BCT8002H	Low-Cost, Mono 2.2W Audio Power Amplifier High Enable	AB	1.5	2.5-5.5	0.1	1	-64	SOP8	APA3011/ECL4890 EMA1001/EUA6204A LM4876/LM4889/LM4890 TPA751/6203/6205/6211 TS4990
BCT8890	Low-Cost, Mono 2.2W Audio Power Amplifier	AB	1.5	2.5-5.5	0.1	1	-64	MSOP8 DFN2x2-8L DFN3x3-8L	IS31AP4991/4991A/4996 APA3010/EMA2004 TPA301/321/701/721/741 TS4871/TS4890
BCT8890H	Low-Cost, Mono 2.2 W Audio Power Amplifier High Enable	AB	1.5	2.5-5.5	0.1	1	-64	MSOP8 DFN2x2-8L DFN3x3-8L	APA0714/APA3011/ECL4890 EMA1001/1002/2001 EUA4890/EUA6204/TS4990 LM4876/4889/4890/4990 SGM4890/4891/4895/4995
*BCT8996	Low-Cost, Mono 2.2W Audio Power Amplifier	AB	1.5	2.5-5.5	0.1	1	-64	MSOP8 DFN3x3-10L	SGM4996
BCT8005/L	Low-Cost, Mono 2.8W Audio Power Amplifier	D	1.67	2.8-5.5	0.11	0.1	-80	SOP8 MSOP8 DFN2x2-8L	XX8005/PAM8303C RT9010/SSM2305 EMA2011/TPA2005
BCT8012/3	Low-Cost, Mono 2.8W Audio Power Amplifier	D	1.67	2.8-5.5	0.11	0.1	-80	QFN1.5x1.5-9L	AW8010/PAM8013
BCT8933/B	Class T Audio Amplifier	T	2	2.5-5.5	0.03 0.06	0.1	-70	QFN3x3-20L	XX8733
BCT8937S/T/A	Class T Audio Amplifier	T	1.2	3.3-4.35	0.08	1	-68	WCSP-14L FCQFN1.6x1.6-16L	XX8737S
BCT89317/T/A	Class T Audio Amplifier	T	2.15	3.3-4.35	0.08	1	-68	WCSP-14L FCQFN1.6x1.6-16L	XX87317
BCT8327	Class T Audio Amplifier	T+AB	2.15	3.3-4.35	0.02	1	-100	WCSP-14L	XX87327
BCT89318F/T/A	Class T Audio Amplifier	T	2.15	3.3-4.35	0.08	1	-68	WCSP-14L FCQFN1.6x1.6-16L	XX87318

* Please Contact Our Sales Office For More Details

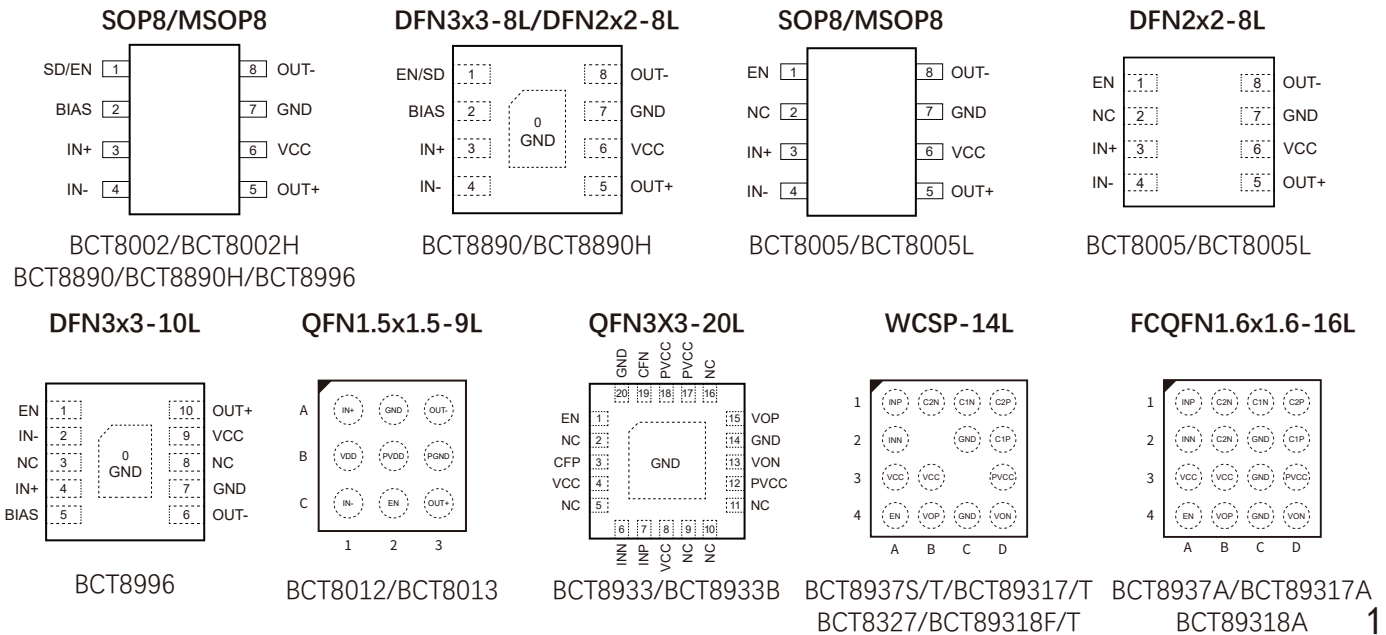

PART No.	Description	V _{IN} Range (V)	I _Q /Channel (mA)	V _{OS} (mV)	PSRR (dB)	Gain Bandwidth (MHz)	Slew Rate (V/μs)	Package	Cross Reference
BCT8321	1 Channel RRIO 1MHz, CMOS Amplifier	2.1-5.5	0.12	±0.8	80	1	0.65	SOT23-5	LMV321A MCP6001 SGM321B
BCT8321B	1 Channel RRIO 1MHz, CMOS Amplifier	2.1-5.5	0.12	±0.8	80	1	0.65	SOT23-5	LMV321 MCP6L01U SGM321
BCT8358	2 Channel RRIO 1MHz, CMOS Amplifier	2.1-5.5	0.06	±0.8	80	1	0.65	SOP8 DFN2x2-8L	LMV358 LMV6002 LM2904LV MCP6002 SGM358
BCT8324	4 Channel RRIO 1MHz, CMOS Amplifier	2.1-5.5	0.06	±0.8	80	1	0.65	SOP14	LMV324 LMV6004 LM2902LV MCP6004 SGM324
BCT8721	1 Channel RRIO 15MHz, CMOS Amplifier	2.1-5.5	2.2	±0.85	85	15	9	SOT23-5	LMV721 TLV9061 TLV316 MCP6291 SGM721
BCT8721B	1 Channel RRIO 15MHz, CMOS Amplifier	2.1-5.5	2.2	±0.85	85	15	9	SOT23-5	TLV9061 TLV316
BCT8722	2 Channel RRIO 15MHz, CMOS Amplifier	2.1-5.5	1.1	±0.85	85	15	9	SOP8 DFN2x2-8L	LMV722 MCP6292 SGM722
BCT8724	4 Channel RRIO 15MHz, CMOS Amplifier	2.1-5.5	1.1	±0.85	85	15	9	SOP14	LMV724 MCP6294 SGM724
*BCT8042	2 Channel RRIO 40KHz, CMOS Amplifier	1.4-5.5	0.0006	±3.5	100	0.014	3.5V/mS	SOP8 MSOP8	SGM8042

* Please Contact Our Sales Office For More Details

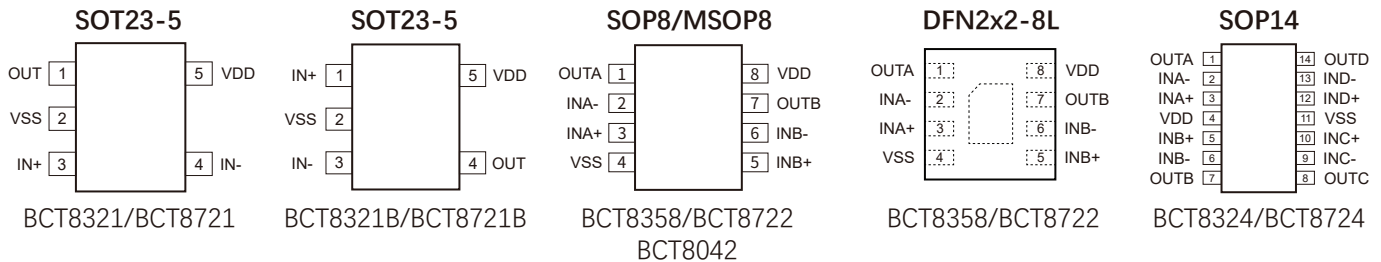

FM LNA

PART No.	Description	V _{CC} Range (V)	I _Q (mA)	Power Gain (dB)	Noise Figure (dB)	Input Return Loss (dB)	Reverse Isolation (dB)	Output Return Loss (dB)	Package	Cross Reference
BCT5007	FM Low Noise Amplifier	2.6-3.6	9.2	21	1.2	-3.7	-39.8	-20.5	SOT363	XX5007 MXXX02C
BCT5037	FM Low Noise Amplifier	2.6-3.6	9.2	21	1.2	-3.7	-39.8	-20.5	DFN1.5x1.0-6L	AW5037

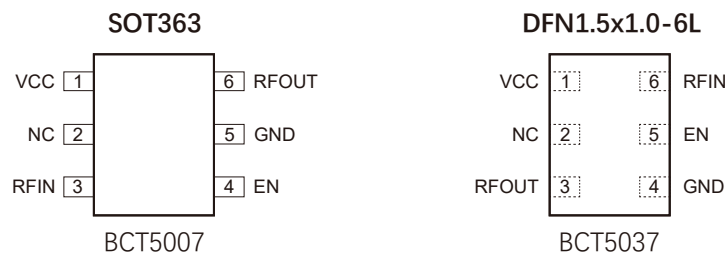

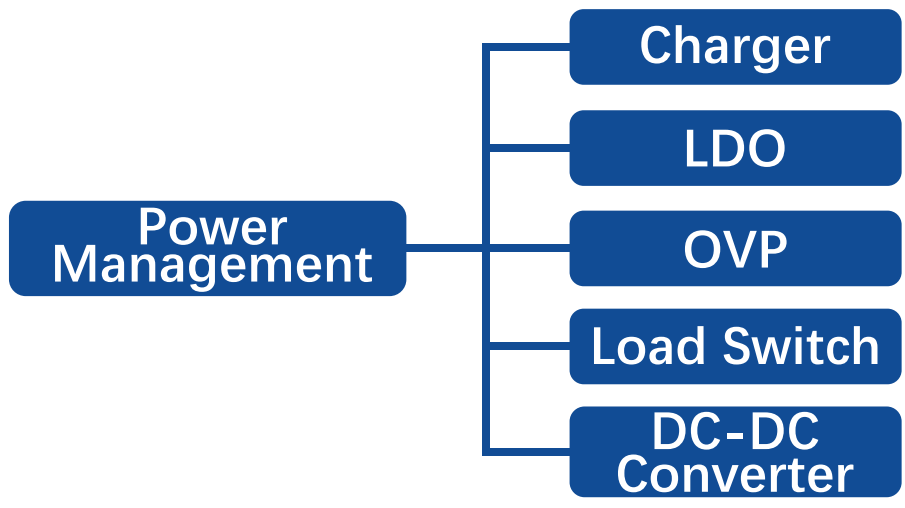
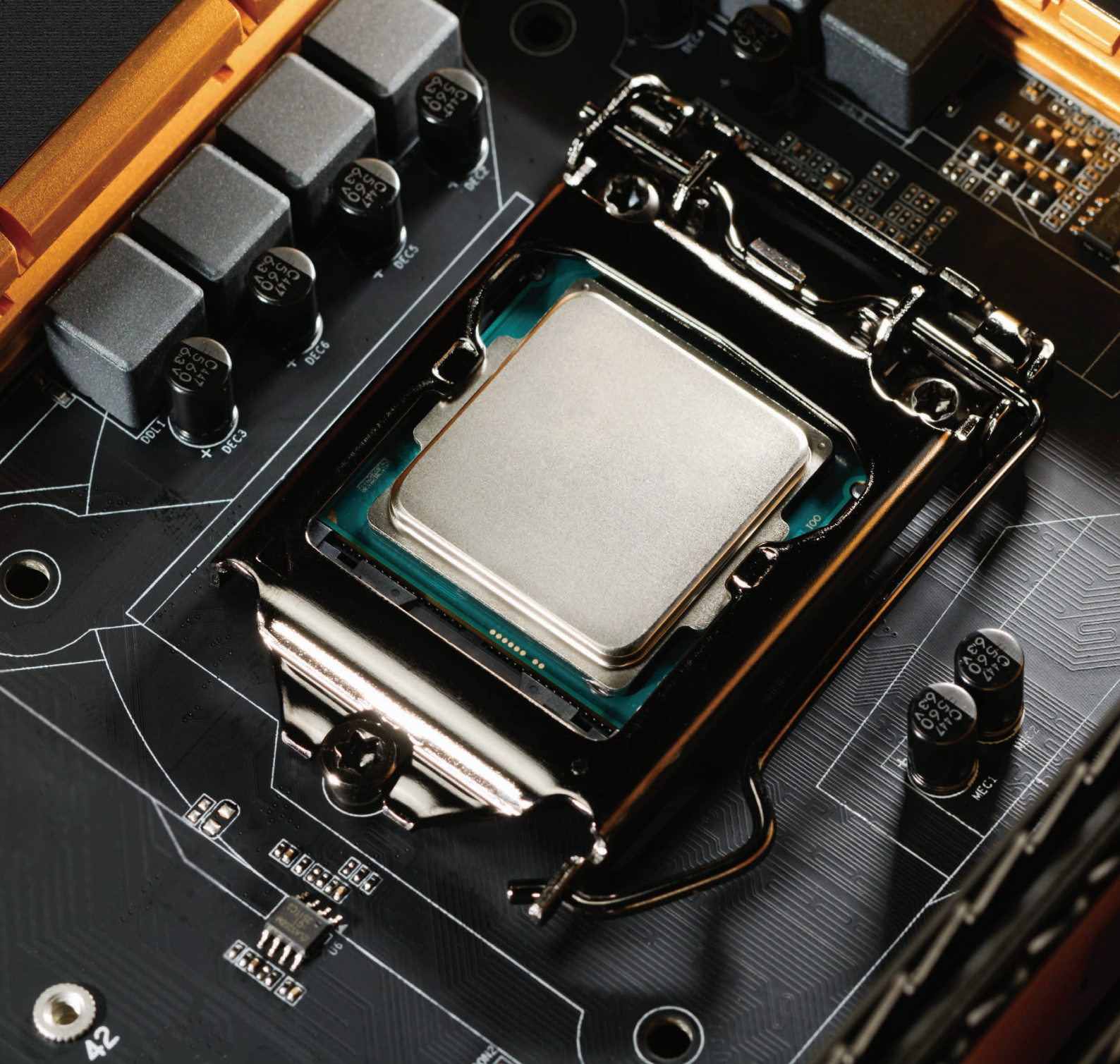

PART No.	Description	Maximum Charge Current (A)	End of Charge Current	V _{BUS} (V)	V _{BUS_MAX} (V)	Charge Voltage Range (V)	Package	Cross Reference
BCT24157	1.5A Single-Cell Li-Ion Switching Charger with USB-OTG Boost Regulator	1.5	C/15	4.0-6.2	24	4.2-4.5	WLCSP-20L	BQ24157 FAN54015 FAN54005
BCT24157D	1.5A Single-Cell Li-Ion Switching Charger	1.5	C/15	4.0-6.2	24	4.2	WLCSP-20L	
BCT2601	3A Single-Cell Li-Ion Switching Charger with USB-OTG Boost Regulator	3	C/50	3.9-13.5	20	3.86-4.62	QFN4x4-24L	BQ25601
BCT4056	1.0A Li-Ion Linear Charger Management	1.0	C/10	4.0-6.5	6.5	4.2-4.35	ESOP8	XXX4056
BCT4054	0.7A Li-Ion Linear Charger Management	0.7	C/10	4.0-6.5	6.5	4.2-4.35	SOT23-5	XXX4054
BCT4057	0.7A Li-Ion Linear Charger Management	0.7	C/10	4.0-6.5	6.5	4.2-4.35	SOT23-6	XXX4057

WLCSP-20L

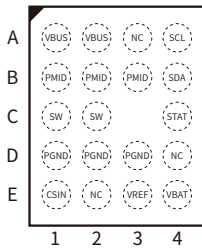

BCT24157/BCT24157D

QFN4x4-24L

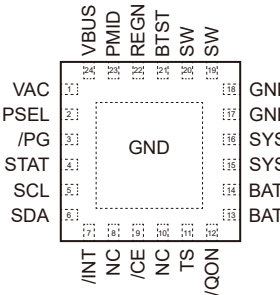

BCT2601

SOT23-5

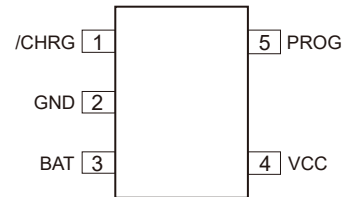

BCT4054

ESOP8

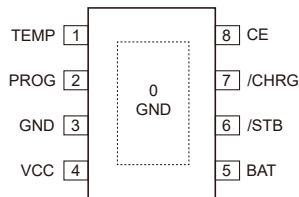

BCT4056

SOT23-6

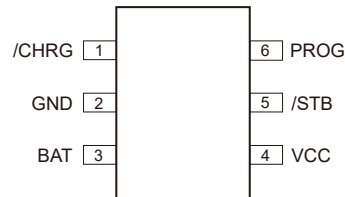

BCT4057

LDO (Low Voltage)

PART No.	Description	V _{IN} Range (V)	V _{OUT} Range (V)	I _Q (uA)	I _{OUT} (mA)	Current Limit (mA)	PSRR (dB@1KHz)	Package	Cross Reference
BCT2020	300mA Low IQ Low Dropout Regulators	1.6-5.5	1.2 1.8 2.8 3.0 3.3 (0.8-5.0)ADJ	20	300	560	70	SC70-5 SOT23-5 UTDFN1x1-4L	SGM2036
BCT2021	300mA Low IQ Low Dropout Regulators	1.6-6.0	1.0 1.2 1.8 2.5 2.8 3.0 3.3	35	300	500	70	SC70-5 SOT23-3 SOT23-5 UTDFN1x1-4L	SGM2036 ETA5053
BCT2036	300mA Low IQ Low Dropout Regulators	1.6-5.5	1.2 1.8 2.8 3.0 3.3 (0.8-5.0)ADJ	20	300	560	75	SC70-5 SOT23-3 SOT23-5 UTDFN1x1-4L	TLV703 SGM2036
BCT2038	500mA Low IQ Low Dropout Regulators	1.6-5.5	1.2 1.8 2.8 3.0 3.3 (0.8-5.0)ADJ	20	500	800	75	SC70-5 SOT23-3 SOT23-5 SOT89-3	TLV755P ME6211
BCT2193	500mA Low IQ Low Dropout Regulators	1.6-5.5	1.2 1.8 2.8 3.0 3.3	20	500	800	70	SOT23-3 SOT89-3	TLV755P
BCT2211	500mA Low IQ Low Dropout Regulators	1.6-5.5	1.2 1.8 2.8 3.0 3.3 (0.8-5.0)ADJ	20	500	800	70	SC70-5 SOT23-5	TLV755P
BCT2561	2uA IQ, Low Dropout Regulators	1.6-5.5	0.75 0.8 1.05 1.2 1.3 1.5 1.8 1.85 2.5 2.8 3.0 3.3	2	300	550	70	SOT23-3 SOT23-5 UTDFN1x1-4L	XC6233 RP110L RT9073 TPS7A05
BCT2562	2uA IQ, Low Dropout Regulators	1.6-5.5	0.8 0.9 1.2 1.3 1.5 1.8 1.85 2.5 2.8 3.0 3.3	2	600	1000	70	SOT23-3 SOT23-5 UTDFN1x1-4L	XC6233 RP110L RT9073 TPS7A05

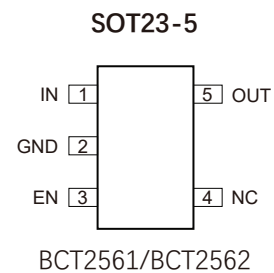
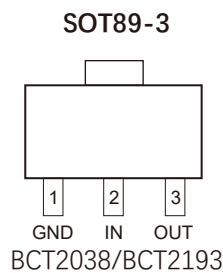
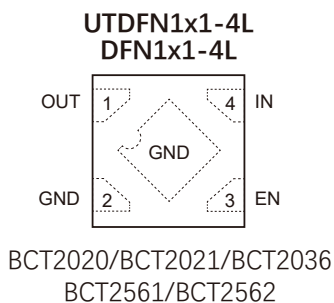
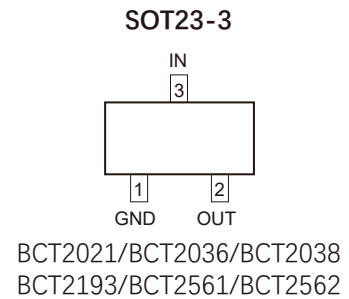
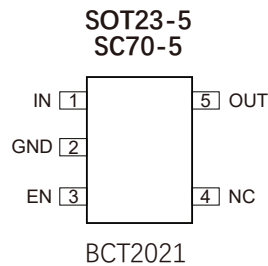
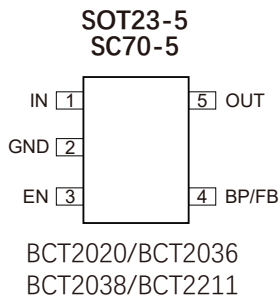

LDO (Low Voltage)

PART No.	Description	V _{IN} Range (V)	V _{OUT} Range (V)	I _Q (uA)	I _{OUT} (mA)	Current Limit (mA)	PSRR (dB@1KHz)	Package	Cross Reference
BCT2040	1000mA Low Dropout Regulators	2.2-6.0	1.0 1.2 1.5 1.8 2.5 2.8 3.0 3.3 5.0 (0.8-5.0)ADJ	30	1000	1800	60	ESOP8	AP7361C
BCT2057	1000mA Low Dropout Regulators	1.6-5.5	0.8 0.9 1.0 1.05 1.1 1.2 1.3 1.35 1.5 1.8 2.2 2.5 2.8 3.0 3.3 3.6 (0.8-5.0)ADJ	30	1000	1800	60	SOT23-5 DFN2x2-6L	TLV757 XC6227
BCT2910	Ultra Low Noise and High PSRR LDO Regulators	1.8-5.5	1.2 1.5 1.8 2.5 2.8 3.0 3.3 4.2 5.0	14	300	530	94	WLCSP-4L	LP5910
BCT2160	Ultra Low Noise and High PSRR LDO Regulators	1.8-5.5	1.2 1.5 1.8 2.5 2.8 3.0 3.3 4.2 5.0	14	300	530	94	SOT23-5 DFNFC1x1-4L	NCP160 TPS7A20 LP5907 SGM2033
BCT2186	1000mA Ultra Low Dropout Regulators	1.8-5.5	0.8 0.9 1.0 1.05 1.1 1.2 1.3 1.35 1.5 1.8 2.2 2.5 2.8 3.0 3.3 3.6 (0.8-5.0)ADJ	30	1000	1400	75	DFN1.6x1.2-8L	NCP186 RP115
BCT2186L	1000mA Ultra Low Dropout Regulators	1.6-5.5	(0.6-5.0)ADJ	30	1000	1400	75	DFN2x2-6L	

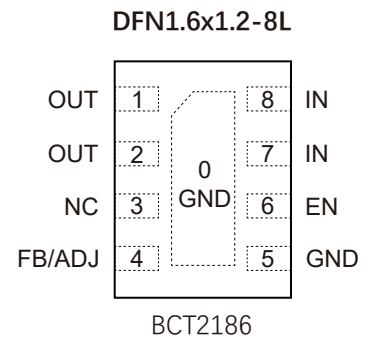
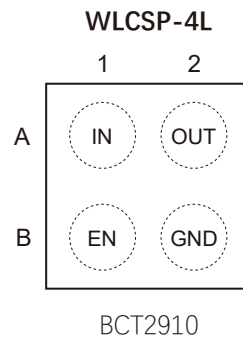
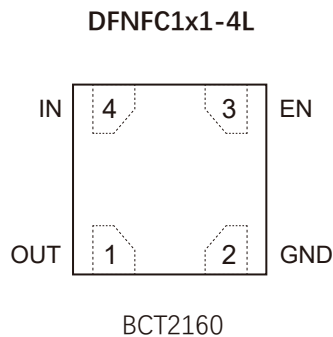
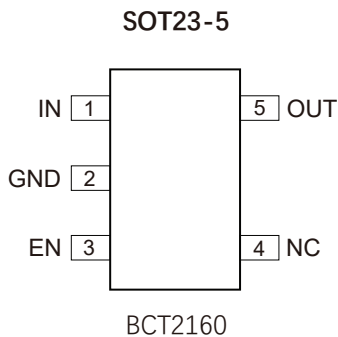
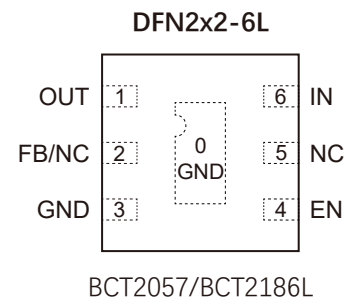
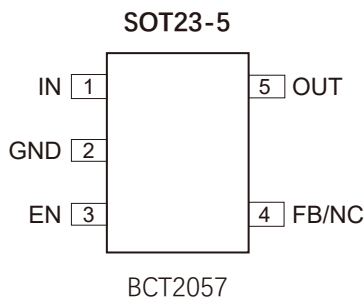
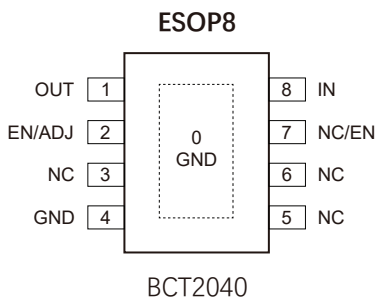

LDO (High Voltage)

PART No.	Description	V _{IN} Range (V)	V _{OUT} Range (V)	I _Q (uA)	I _{OUT} (mA)	Current Limit (mA)	PSRR (dB@1KHz)	Dropout(3.3V) (mV)	Package	Cross Reference
BCT2014	0.7uA IQ Low Dropout Regulators	2.5-15	1.5 1.8 2.5 2.8 3.0 3.3 4.2 4.5 5.0	0.7	300	500	40	320	SC70-5 SOT23-3 SOT23-5 SOT89-3 UTDFN1X1-4L	XC6233 RP110L RT9073
BCT2203	2.5uA IQ High Voltage Regulators	2.7-36	1.5 1.8 3.0 3.3 4.2 4.5 5.0 8.0 9.0 10.0 12.0	2.5	150	230	40	1300	SOT23-3 SOT23-5 SOT89-3	TLV704 TPS709 SGM2203
BCT78L05A	0.7uA IQ Low Dropout Regulators	5.5-15	5	0.7	300	500	40	320	SOT23-3 SOT89-3	78L05
BCT78L05E	3uA IQ High Voltage Regulators	2.7-36	5	3	150	500	40	1300	SOT23-3 SOT89-3	78L05
BCT78L10E	3uA IQ Low Dropout Regulators	2.7-36	10	3	150	500	40	1300	SOT23-3 SOT89-3	78L05
BCT78L12E	3uA IQ High Voltage Regulators	2.7-36	12	3	150	500	40	1300	SOT23-3 SOT89-3	78L05

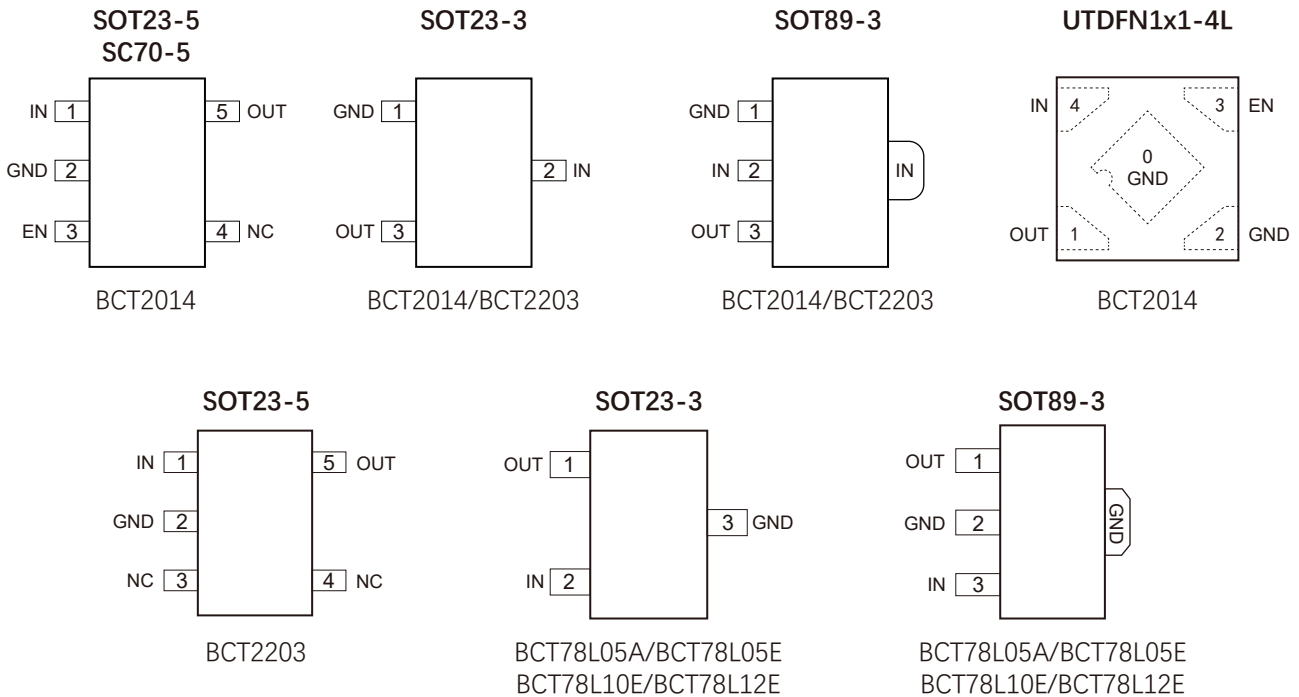

PART No.	Description	R _{DS(on)} (mΩ)	Continuous Current (A)	Peak current (A)	V _{IN_OVLO} (V)	OVP Adjustable Range (V)	V _{IN_MAX} (V)	Surge Protection (V)	Package	Cross Reference
*BCT72901	Over-Voltage Protection Load Switch	30.7	4.5	7	5.95	4-20	29	110	QFNFC1.8x1.3-12L	MAX14655 SGM40655 SGM40658
*BCT72902	Over-Voltage Protection Load Switch	30.7	4.5	7	6.2	4-20	29	110	QFNFC1.8x1.3-12L	FPF3380
BCT72905	Over-Voltage Protection Load Switch	30.7	4.5	7	6.8	4-20	29	110	QFNFC1.8x1.3-12L	MAX14654 MAX14717 SGM40654 SGM40657
*BCT72801	Over-Voltage Protection Load Switch	20	5	8	5.95	4-20	29	120	WLCSP-12L	MAX14655 SGM40655 SGM40658
*BCT72802	Over-Voltage Protection Load Switch	20	5	8	6.2	4-20	29	120	WLCSP-12L	FPF3380
BCT72805	Over-Voltage Protection Load Switch	20	5	8	6.8	4-20	29	120	WLCSP-12L	MAX14654 MAX14717 SGM40654 SGM40657
BCT7915	Over-Voltage Protection Load Switch	30.7	4.5	7	6.8	4-20	29	110	QFNFC1.8x1.3-12L	MAX14655 SGM40655 SGM40658
BCT7925	Over-Voltage Protection Load Switch	30.7	4.5	7	6.8	4-20	29	90	QFNFC1.8x1.3-12L	MAX14655 SGM40655 SGM40658

* Please Contact Our Sales Office For More Details

QFNFC1.8x1.3-12L

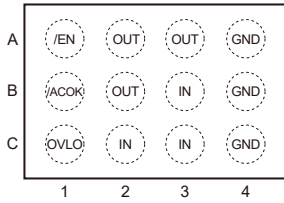

BCT72901/BCT72902
BCT72905/BCT7915/BCT7925

WLCSP-12L

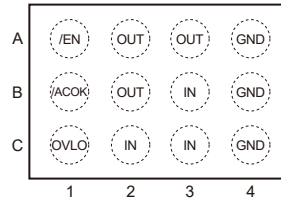

BCT72801/BCT72802/BCT72805

Load Switch

PART No.	Description	V _{cc} (V)	I _q (uA)	R _{on} (mΩ)	I _{lim} (A)	Over-Current Response (uS)	Quick Auto-Discharge	Response FAULT	Package	Cross Reference
BCT6553	Power Distribution Switch	2.5-5.5	62	90	1.7	2	YES	YES	SOT23-6 TDFN2x2-6L	TPS2551 TPS2552 TPS2553 TPS25221 SGM2553

SOT23-6

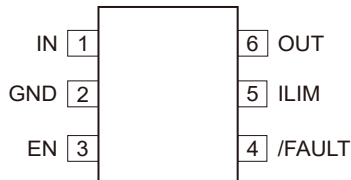

BCT6553

TDFN2x2-6L

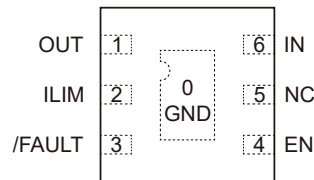

BCT6553

DC-DC Converter

PART No.	Description	Control	V _{IN} Range (V)	V _{OUT} Range (V)	Efficiency (%)	I _{OUT} (mA)	I _Q (uA)	Switch Frequency (KHz)	Package	Cross Reference
* BCT1031	5V 0.2A Buck Converter	PWM	1.8-5.5	1-3.3	95	200	0.4	1400	SOT23-5 DNF2x2-6L	SGM6031 ETA3425
BCT1013	5V 1.2A Buck Converter	PWM	2.5-5.5	0.6-5	95	1200	40	1500	SOT23-5 DNF2x2-6L	TPS62260 TPS62240 NCP1521B SGM6013
BCT12569	5V 2A Buck Converter	PWM	2.7-5.5	0.6-5	95	2000	55	1000	SOT563	TLV62569 MP1605
BCT1810	5V 1A Buck Converter	PWM	2.5-5.5	0.6-5	95	1000	40	1500	SOT23-5 DFN1.6x1.6-6L	NCP1529 RT8059 TLV62568
BCT1812	5V 1.2A Buck Converter	PWM	2.5-5.5	0.6-5	95	1200	40	1500	SOT23-5	NCP1529 RT8059 SGM6012 SGM6018
BCT1813	5V 1.2A Buck Converter	PWM	2.5-5.5	0.6-5	95	1200	40	1500	SOT23-6	RT8096D TLV62568
BCT1814	5V 2A Buck Converter	PWM	2.7-5.5	0.6-5	95	2000	55	1000	SOT23-5	SY8089 AX3702
BCT1815	5V 2A Buck Converter	PWM	2.7-5.5	0.6-5	95	2000	55	1000	SOT23-6	RT8097D TLV62569
* BCT1816	3.4V 2A Buck Converter	PWM	2.7-6.0	0.6-3.4	95	2000	22	1000	SOT23-5 SOT23-6	RT8097C
* BCT1470	17V 2A Buck Converter	ACOT	4.5-17	0.768-6.5	94	2000	380	600	SOT23-6	TPS562208 TPS562201 TPS563240 MP1470
BCT1473	17V 3A Buck Converter	ACOT	4.5-17	0.768-6.5	94	3000	380	600	FCSOT23-6	TPS563201
BCT1477	17V 3A Buck Converter	ACOT	4.5-17	0.768-6.5	94	3000	380	600	FCSOT563	MP1477 MP1660
BCT1451	42V 0.6A Buck Converter	PWM	5-42	0.8-24	95	600	14	1200	SOT23-6	SGM61410 MP2457 MP2460

* Please Contact Our Sales Office For More Details

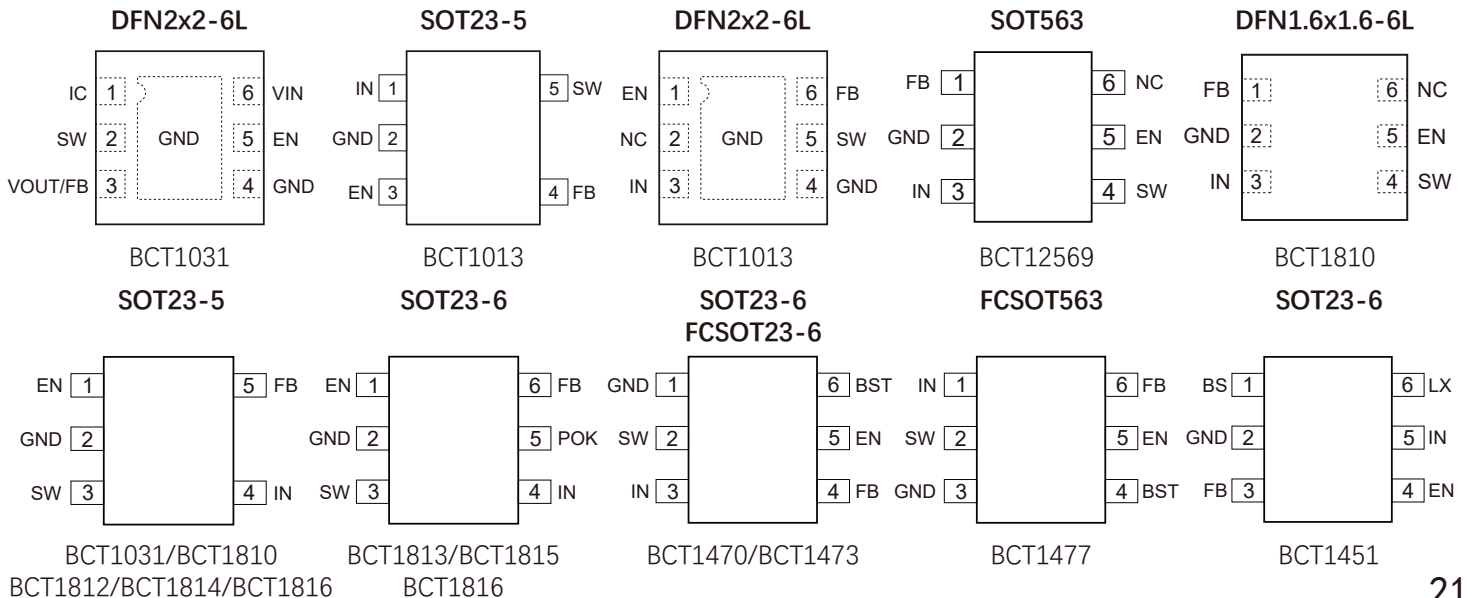

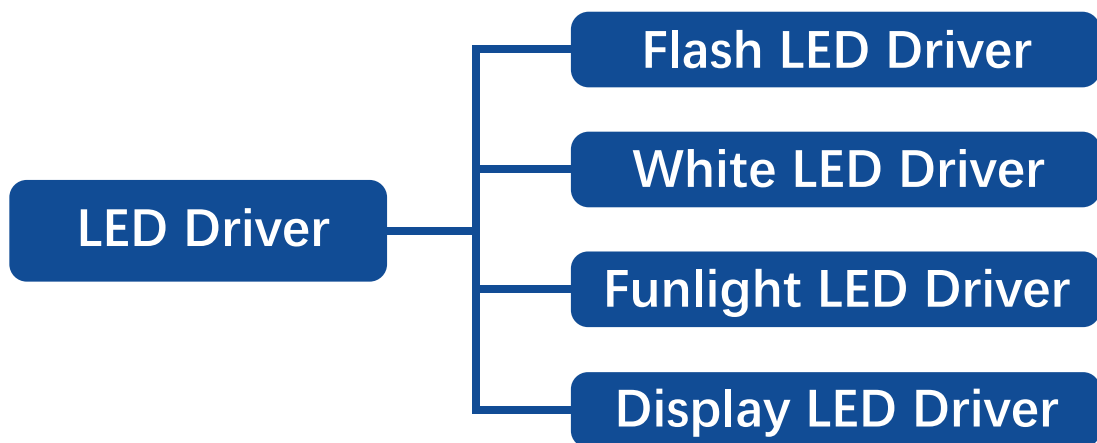

Flash LED Driver

PART No.	Description	V _{IN} (V)	I _a (mA)	IOUT-Flash Mode (mA)	IOUT-Torch Mode (mA)	VOUT Turn-on Time (µs)	Freq (MHz)	Mode	Efficiency	Package	Cross Reference
BCT3140	1A Buck/Boost Charge Pump LED Driver	2.7-5.5	0.3	1000	400	250	1.5	1X/2X	90%	DFN3x3-10L	LM2753 SP6685 SGM3140
BCT3142	1.1A Buck/Boost Charge Pump LED Driver	2.7-5.5	0.4	1100	400	400	1.9	1X/2X	92%	DFN3x3-10L	AW3641E
BCT3144	1.5A x2 Output Flash LED Driver	2.7-5.5	0.6	1500	748	-	2	FLASH TORCH	85%	WLCSP-12L	LM3644 OCP81373
BCT3146	2.0A x2 Output Flash LED Driver	2.7-5.5	0.6	2000	1000	-	2	FLASH TORCH	85%	WLCSP-12L	LM3644 OCP81375

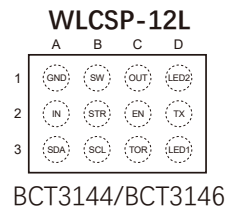
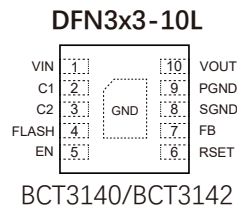

White LED Driver (Serial)

PART No.	Description	Topology	LED Connection	CH	V _{CC} (V)	V _{REF} (mV)	I _{LIM} (mA)	Switching Frequency (KHz)	V _{OV} (V)	Package	Cross Reference
BCT3692B	High Performance, Asynchronous Boost for 10 WLED Driver	BOOST	PWM	1	2.7-5.5	200	1500	1100	38	SOT23-6 TSOT23-6	AP3019A RT4533 RT4526 SGM3752
BCT3756/E	WLED Driver with PWM Brightness Control in Small Package	BOOST	PWM	1	2.7-5.5	200	1500	1100	38	DFN2x2-6L	TPS61161A TPS61165 RT4503A SGM3756
BCT3401	Backlight Driver	BUCK	PWM/PFM	1	2.5-5.5	100	1800	1100		SOT23-5	LN2401

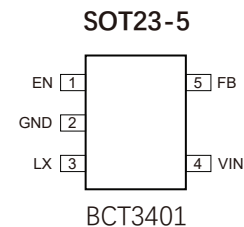
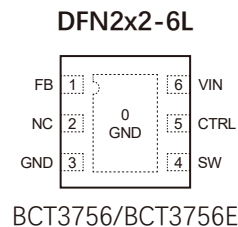
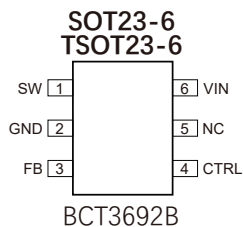

White LED Driver (Parallel)

PART No.	Description	LED connection	V _{CC} (V)	V _{drop} (20mA) (mV)	MAX LED Current/CH (mA)	Bright Level	Current Matching	Package	Cross Reference
BCT3220	4 Channel 8 Steps LED Driver	Common-Anode	2.7-5.5	55	20	8	1.50%	DFN2x2-8L	
BCT3364	4 Channel 16 Steps LED Driver	Common-Anode	2.7-5.5	50	20	16	1.50%	DFN2x2-8L	XX9364
BCT3256	6 Channel 16 Steps LED Driver	Common-Anode	2.7-5.5	55	20	16	1.50%	QFN3x3-16L	XX3256 XX9666

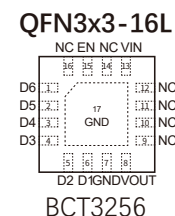
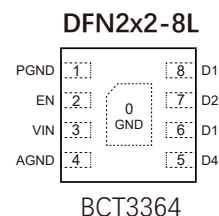
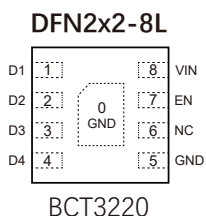

PART No.	Description	Channels	MAX LED Current/CH (mA)	MAX Output Current Setting	Bright level	Vcc (V)	Control	Current match	Package	Cross Reference
BCT3119	9-Channel 64 steps Constant-Current LED Driver	9	40	R_EXT	64	3.1-5.5	SPI	±1%	QFN3x3-20L	
BCT3288A	16-Channel 64 steps Constant-Current LED Driver	16	40	R_EXT	64	3.1-5.5	SPI	±1%	QFN4x4-24L	
BCT3656	16-Channel 64 steps Constant-Current LED Driver	16	40	R_EXT	64	3.1-5.5	SPI	±1%	SOP24 SSOP24-1.0	
BCT3016	16-Channel 256 steps Constant-Current LED Driver	16	45	R_EXT	-	3.3-5.0	SPI	±3%	SSOP24-1.0 SSOP24-0.635 QFN4x4-24L	MBI5024
BCT3024	24-Channel 256 steps Constant-Current LED Driver	24	38	R_EXT	256	2.7-5.5	I2C	-	QFN4x4-32L	LP5024
BCT3236	36-Channel 256 steps Constant-Current LED Driver	36	38	R_EXT	256	2.7-5.5	I2C	-	QFN5x5-44L	IS31FL3236A

QFN3x3-20L

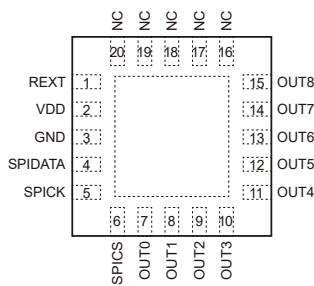

BCT3119

QFN4x4-24L

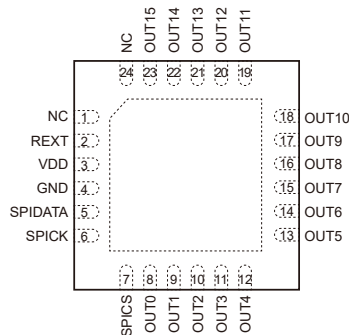

BCT3288A

SOP24
SSOP24-1.0

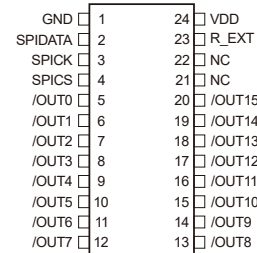

BCT3656

QFN4x4-24L

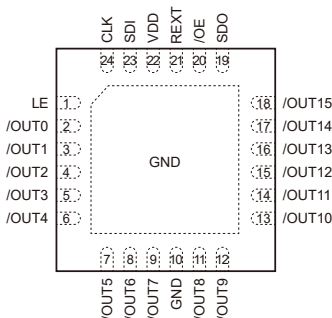

BCT3016

SSOP24-1.0
SSOP24-0.635

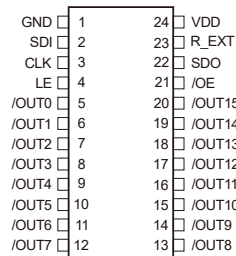

BCT3016

QFN4x4-32L

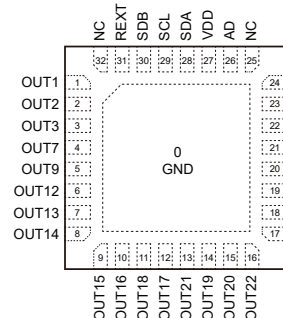

BCT3024

QFN5x5-44L

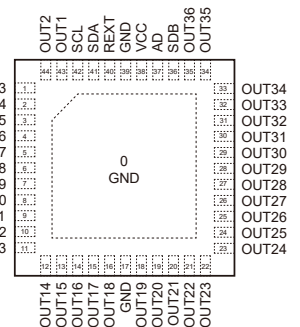

BCT3236

Display LED Driver

PART No.	Description (SEG x GRID)	MAX Operating Temp. (°C)	Dots	MAX LED Current/CH (mA)	Bright level	V _{CC} (V)	Control	Current match	Package	Cross Reference
* BCT3616	7x4 Dots LED Driver	85	28	50	8	3.1-5.5	SPI	±5%	SOP16	XXX1616
* BCT3617	7x3 Dots LED Driver +6x1 keys	85	21	50	8	3.1-5.5	SPI	±5%	SOP16	XXX1617
* BCT3618	7x5 Dots LED Driver +5x1 keys	85	35	50	8	3.1-5.5	SPI	±5%	SOP18	XXX1618
* BCT3620	8x6 Dots LED Driver	85	48	50	8	2.7-5.5	SPI	±5%	SOP20	XXX1620
* BCT3620B	6x7 Dots LED Driver +6x1 keys	85	42	50	8	2.7-5.5	SPI	±5%	SOP20	XXX1620B
* BCT3622	8x5 Dots LED Driver +8x2 keys	85	40	50	8	3.1-5.5	SPI	±5%	SOP20	MC2003

* Please Contact Our Sales Office For More Details

SOP16

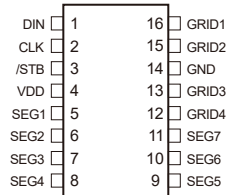

BCT3616

SOP16

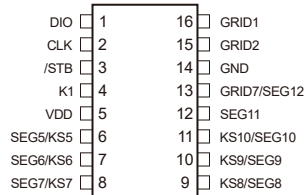

BCT3617

SOP18

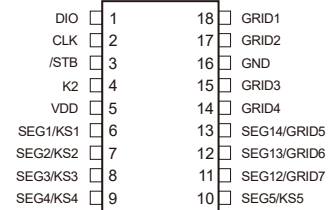

BCT3618

SOP20

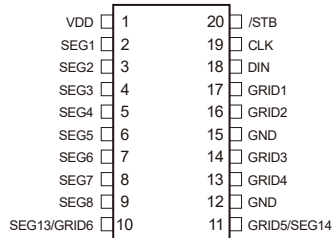

BCT3620

SOP20

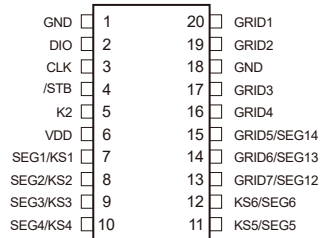

BCT3620B

SOP20

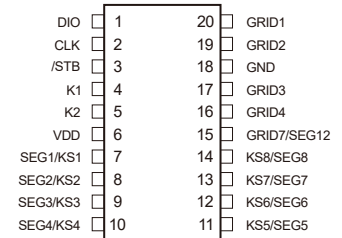

BCT3622

Display LED Driver

PART No.	Description (SEG x GRID)	MAX Operating Temp. (°C)	Dots	MAX LED Current/CH (mA)	Bright level	V _{CC} (V)	Control	Current Match	Package	Cross Reference
BCT3668/R	10x7 Dots LED Driver +10x2 keys	85	70	50	8	3.0-5.5	SPI	±5%	SOP24 SSOP24-0.635	XXX1668
HOT! BCT3668A	10x7 Dots LED Driver +10x2 keys with slope function	85	70	50	256	3.0-5.5	SPI	±5%	SOP24 QFN4x4-28L	XXX1668
HOT! BCT1668/T	10x7 Dots LED Driver +10x2 keys	105 🔥	70	50	8	3.0-5.5	SPI	±5%	SOP24 SSOP24-0.635	XXX1668
HOT! BCT3628/R	10x7 Dots LED Driver +10x2 keys	85	70	50	8	3.0-5.5	SPI	±5%	SOP28	XXX1628
HOT! BCT1628/T	10x7 Dots LED Driver +10x2 keys	105 🔥	70	50	8	3.0-5.5	SPI	±5%	SOP28	XXX1628
HOT! BCT3628A	10x7 Dots LED Driver +10x2 keys with slope function	86	70	50	256	3.0-5.5	SPI	±5%	SOP28	XXX1628
* BCT3627	10x7 Dots LED Driver +10x2 keys	85	70	50	8	3.0-5.5	SPI	±5%	SOP28	XXX1627
* BCT3623	11x7 Dots LED Driver +10x3 keys	85	77	50	8	3.0-5.5	SPI	±5%	SOP32	XXX1623
BCT3624	11x7 Dots LED Driver	85	77	50	8	3.0-5.5	SPI	±5%	SOP24	XXX1624

* Please Contact Our Sales Office For More Details

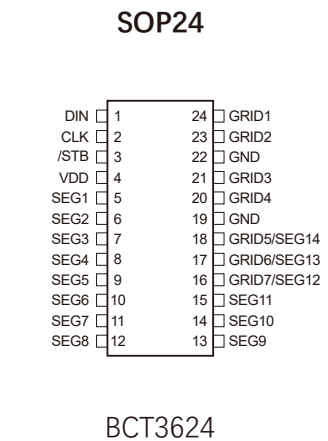
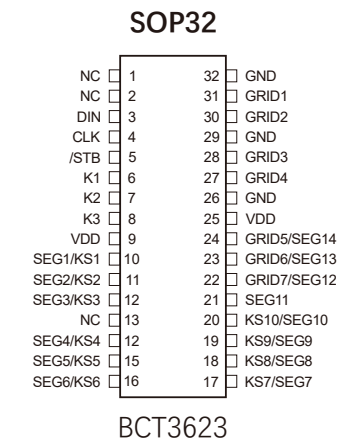
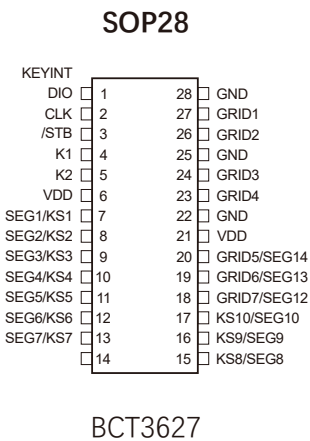
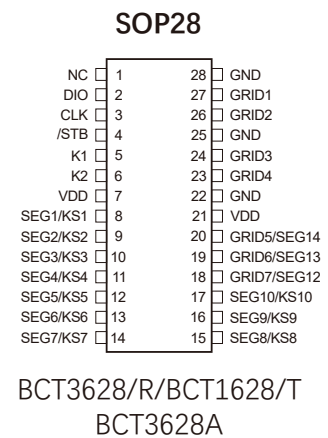
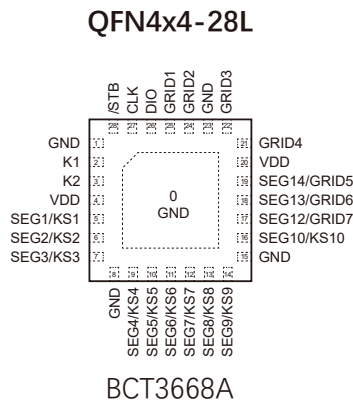
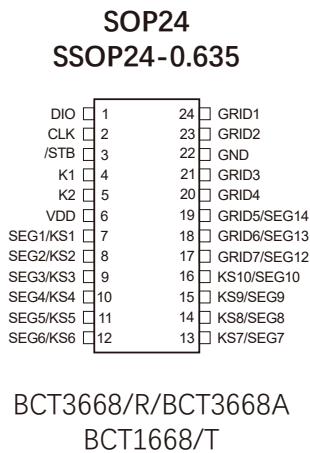

Display LED Driver

PART No.	Description (SEG x GRID)	MAX Operating Temp. (°C)	Dots	MAX LED Current/CH (mA)	Bright level	Vcc (V)	Control	Current match	Package	Cross Reference
BCT3640	8x16 Dots LED Driver	85	128	50	8	3.0-5.5	SPI	-	SOP28 SSOP28	XXX1640
HOT! BCT1640/T	8x16 Dots LED Driver	105	128	50	8	3.0-5.5	SPI	-	SOP28 SSOP28	XXX1640
* BCT3629A	16x8 Dots LED Driver	85	128	50	8	3.0-5.5	SPI	±5%	SOP32	XXX1629A
* BCT3629B	14x8 Dots LED Driver +8x2 keys	85	112	50	8	3.0-5.5	SPI	±5%	SOP32	XXX1629B
* BCT3629C	15x8 Dots LED Driver +8x1 keys	85	120	50	8	3.0-5.5	SPI	±5%	SOP32	XXX1629C
* BCT3629D	12x8 Dots LED Driver +8x4 keys	85	96	50	8	3.0-5.5	SPI	±5%	SOP32	XXX1629D
* BCT3638	10x8 Dots LED Driver +8x3 keys	85	80	50	8	3.0-5.5	SPI	±5%	SOP28	XXX1638
* BCT3639	8x8 Dots LED Driver +4x2 keys	86	64	50	8	3.0-5.5	SPI	±5%	SOP24	XXX1639
* BCT3932	8x16 Dots LED Driver	85	128	50	8	3.0-5.5	SPI	±5%	SOP32	TA6932

* Please Contact Our Sales Office For More Details

SOP32

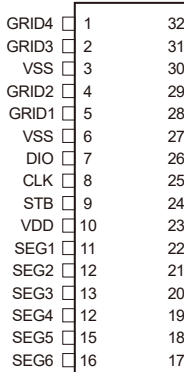

BCT3629A

SOP32

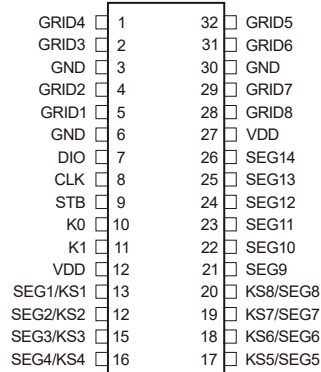

BCT3629B

SOP32

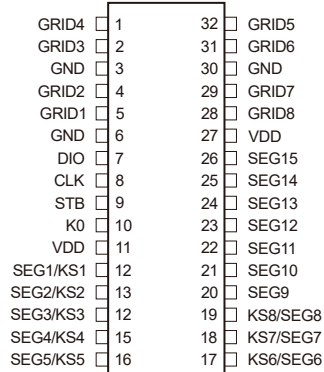

BCT3629C

SOP32

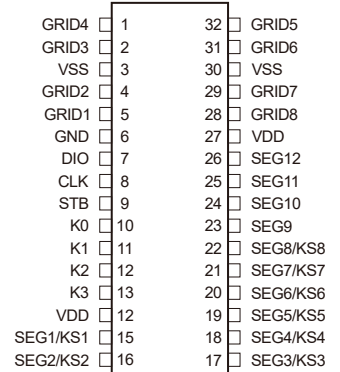

BCT3629D

SOP28 SSOP28

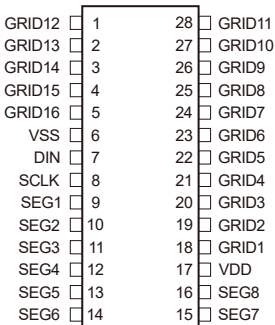

BCT3640/BCT1640/T

SOP28

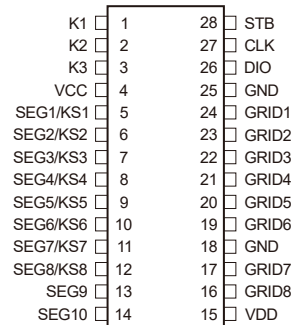

BCT3638

SOP24

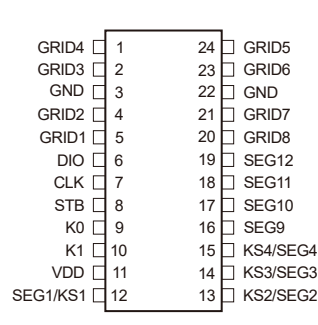

BCT3639

SOP32

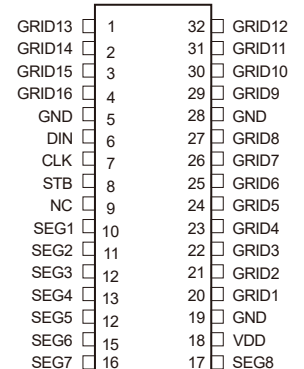

BCT3932



Level Shifter

Bidirectional
Level Shifter

Multiple SIM Card
Controller

Bidirectional Level Shifter

PART No.	Description	Vref_A(Min) (V)	Vref_B(Min) (V)	I _q (μ A)	I _o /Continuous Current (mA)	Max Data (Mbps) Rate	No. of Bits	Package	Cross Reference
BCT0102	2Bit Bidirectional Level-Shifting	1.65	2.3	7.1	\pm 50	24	2	TSOT23-8 QFN1.4x1.2-8L XTDFN1.4x1.0-8L	TXS0102 FXMAR2102 SGM4553 SGM4556
BCT0104	4Bit Bidirectional Level-Shifting	1.65	2.3	7.1	\pm 50	24	4	FO-12L TQFN3x3-16L QFN3.5x3.5-14L	TXS0104E FXMAR2104

TSOT23-8

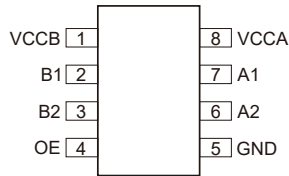

BCT0102

XTDFN1.4x1.0-8L

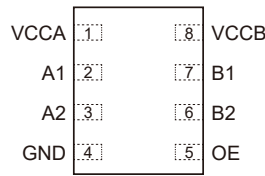

BCT0102

QFN1.4x1.2-8L

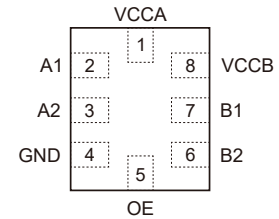

BCT0102

TQFN3x3-16L

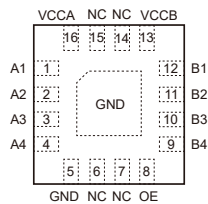

BCT0104

QFN3.5x3.5-14L

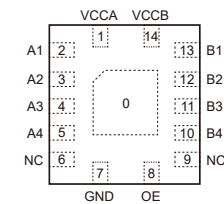

BCT0104

FO-12L

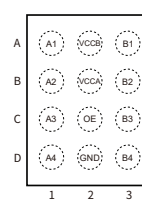

BCT0104

Multiple SIM Card Controller

PART No.	Description	V _{IN} (V)	Operating Current (μ A)	V _{IO} Operating Voltage (V)	SIM Card Supplies (V)	Output Current Limit (mA)	SCLK Frequency (MHz)	Package	Cross Reference
BCT4302B	Dual SIM Card Controller	2.7-5.5	30	1.65-5.5	1.8/3.0	38	5	QFN3x3-20L	MT6302
BCT4306	Multipel SIM Card Controller	3.2-4.3	25	1.6-3.2	1.8/3.0	38	5	QFN4x4-28L	MT6306

QFN3x3-20L

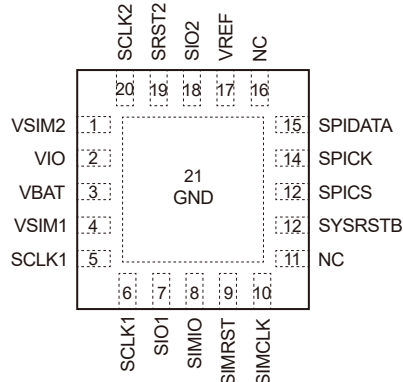

BCT4302B

QFN4x4-28L

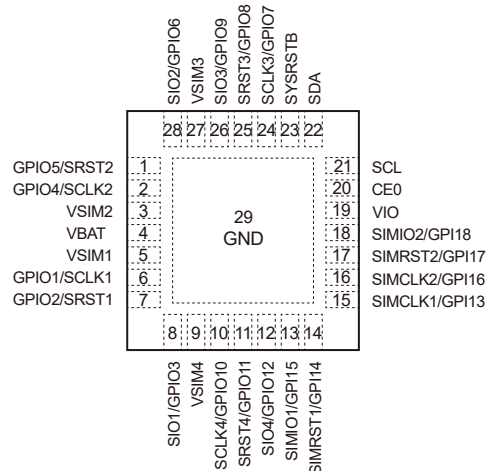

BCT4306

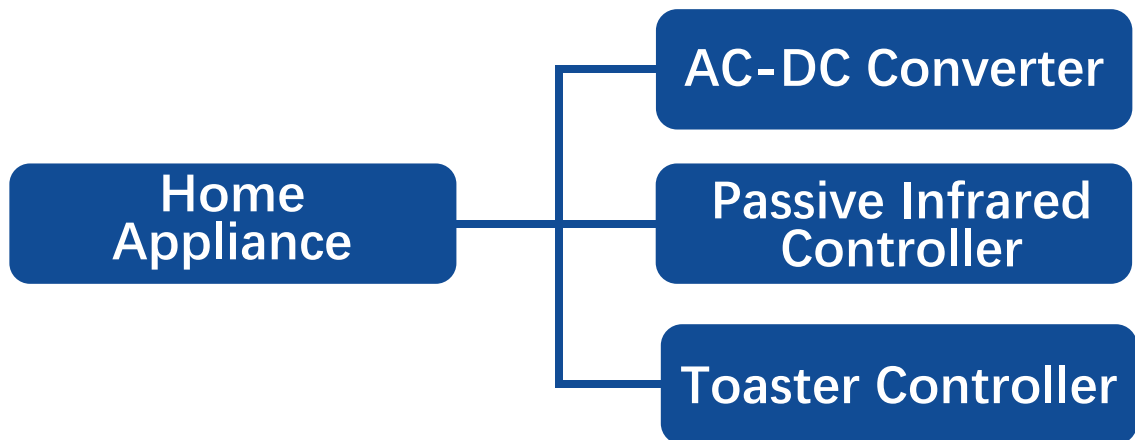

AC-DC Converter

PART No.	Description	SW (V)	R _{DS(on)} (Ω)	V _{DD} (V)	Current Limit (mA)	P _{OUT} (W)	Package
BCT5034	Non-isolation Power Converter	650	10	10-20	750	2.4	DIP7 SOP-7
BCT5055	Non-isolation Power Converter	650	10	10-20	750	2.4	SOP-7

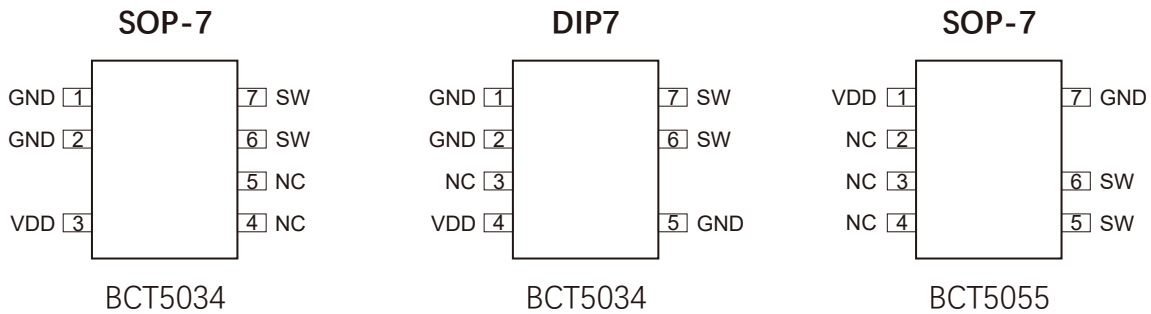

Passive Infrared Controller

PART No.	Description	V _{DD} (V)	I _{DD} (μA)	V _{SO} (mV)	AVO (dB)	CMMR (dB)	Package
BCT0001	PIR Sensor Controller	3.0-5.0	50	25	60	60	SOP16

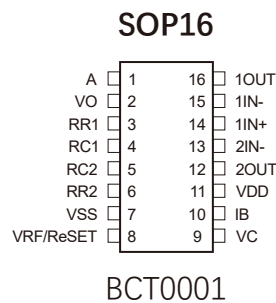

Toaster Controller

PART No.	Description	Operating voltage (V)	I _{CC} (μA)	I _{OH} (mA)	I _{OL} (mA)	NTC Adjust	No OSC Protect	Defrost	Reheat	Package
BCT5512	Toaster Controller	4.0-5.5	100	-1	0.2	√	√	—	—	TO94 SOT23-5

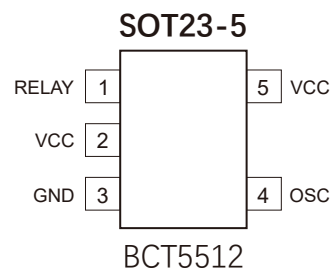
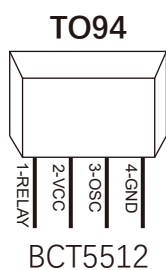

Broadchip Total Solutions

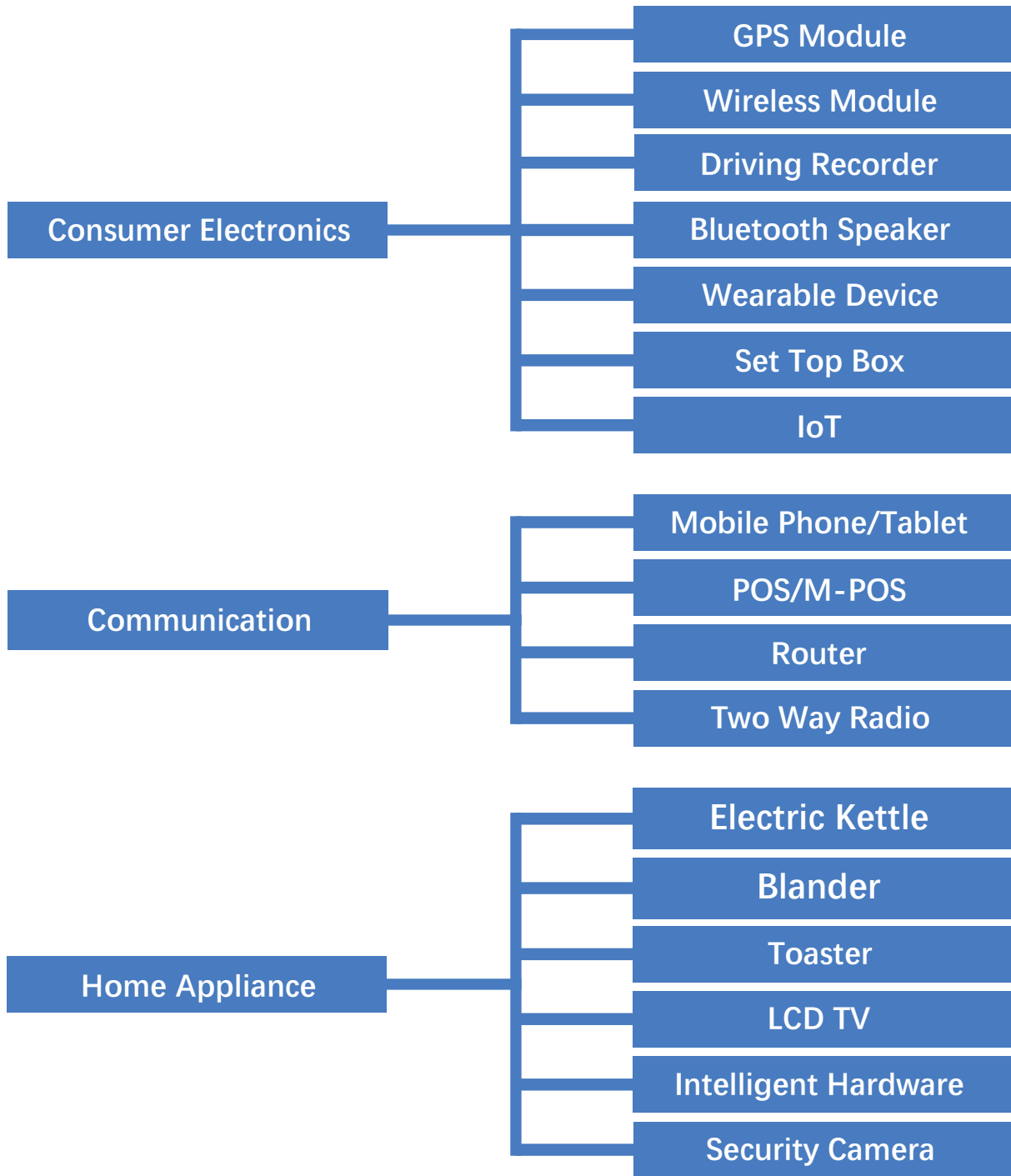

Mobile Phone Solution

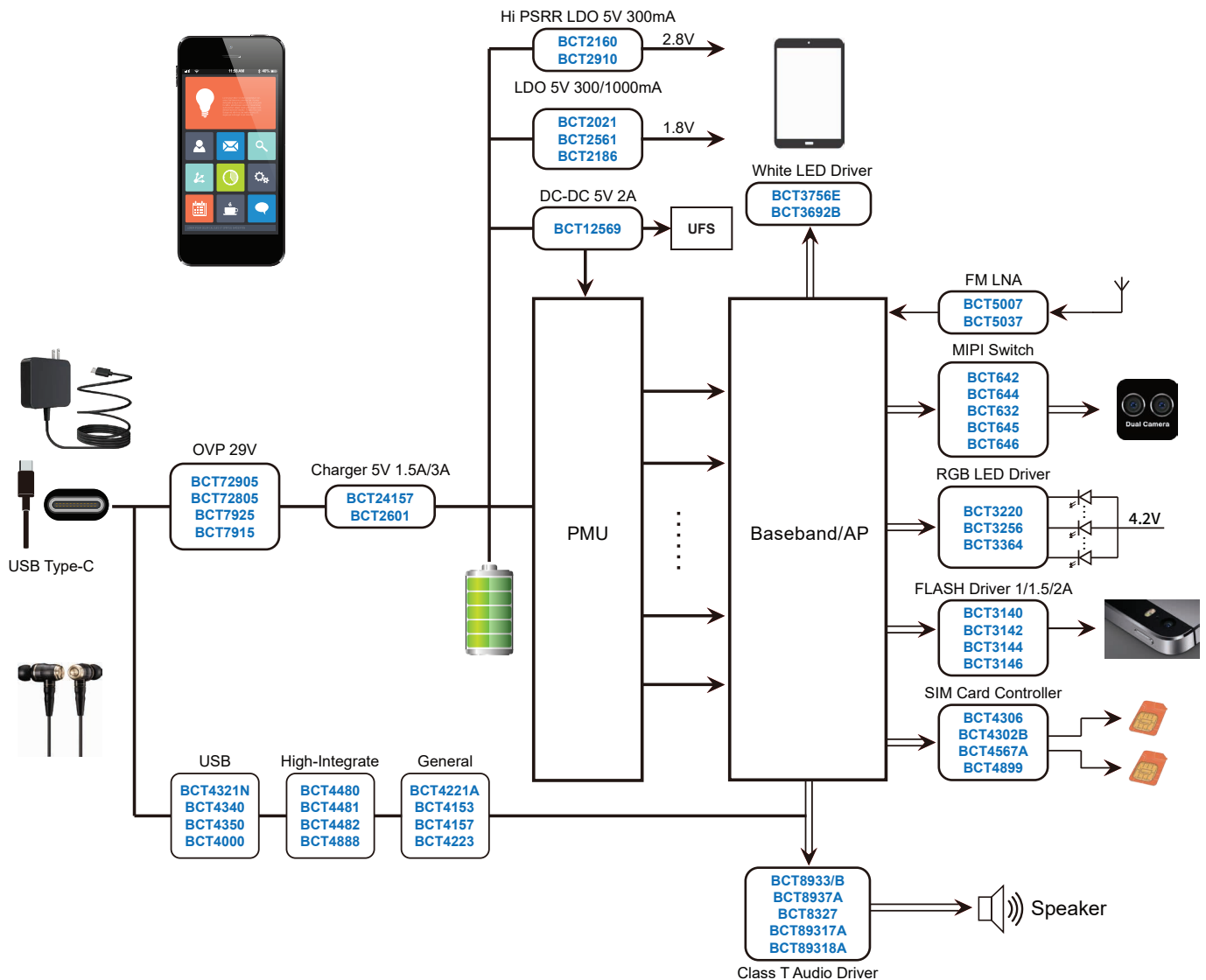

BCT3756E/BCT3692B

250:1 PWM Control LED Driver 38V High Efficiency, Boost WLED Driver with PWM Control

BCT4480

USB Type-C Analog Switch with Protection Function

BCT2036

300mA Low IQ Dropout Regulators

BCT2186

1000mA Ultra Low Dropout Regulators

BCT5007

FM Low Noise Amplifier in Alliance with Internal Antenna

BCT2160/BCT2910

Ultra Low Noise and High PRSS LDO Regulators

BCT634

2:1 MIPI D-PHY, C-PHY(2.5Gbps) 4-Data Lane Switch (0.35Pitch)

BCT644

2:1 MIPI D-PHY (2.5Gbps) 4-Data Lane Switch

BCT636

2:1 MIPI D-PHY, C-PHY (4.5Gbps) 4-Data Lane Switch (0.35Pitch)

BCT89318A

High Efficiency, Low Noise, Ultralow Distortion, Constant Large Volume Class T Audio Amplifier

BCT8933/BCT8933B

High Power, Low THD+N Class T Audio Amplifier

Analog Switch

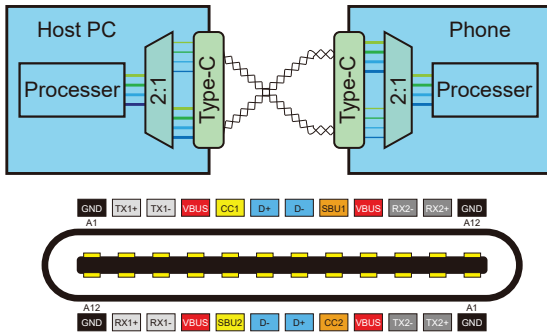

TQFN4.5x2.5-20L

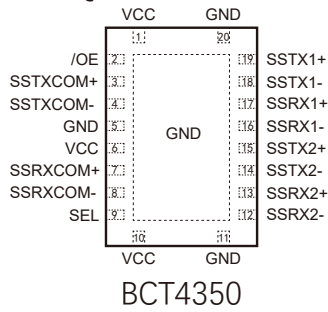

BCT4350 - USB3.1 SuperSpeed 10 Gbps Switch

Features

- 10 GHz Typical Bandwidth
- USB 3.1 SuperSpeed 5Gbps and 10 Gbps Switch
- -1.0 dB Typical Insertion Loss at 2.5 GHz
- Wide VDD Operating Range, 1.5 V-5.0 V
- Low Active Power of 12 μ A Typical
- 2 kV HBM ESD Protection
- Low Shutdown Power of < 1 μ A Max
- Small Package, TQFN 4.5x2.5-20L

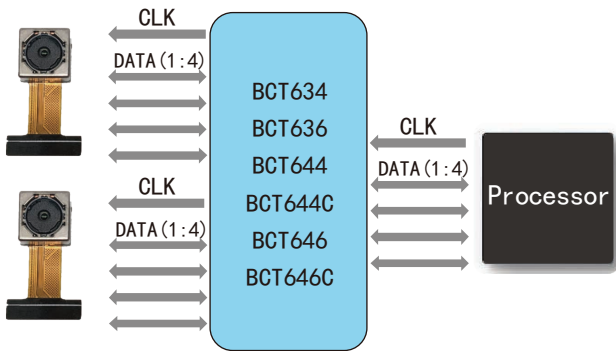

WLCSP-36L

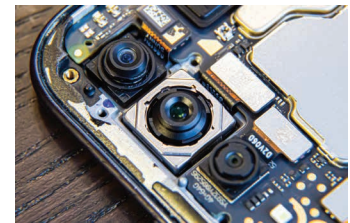
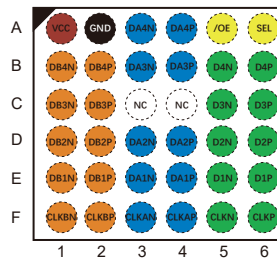

BCT646 - 2:1 MIPI D-PHY(4.5Gbps) 4-Data Lane Switch

Features

- Single Types: MIPI D-PHY, C-PHY
- Ron: 6.5 Ω Typical HS MIPI / 6.5 Ω Typical LP MIPI
- -3dB Bandwidth: 4.5GHz Typical
- ICC: 35uA Maximum
- Con: 1.5pF
- 36-Ball WLCSP Package

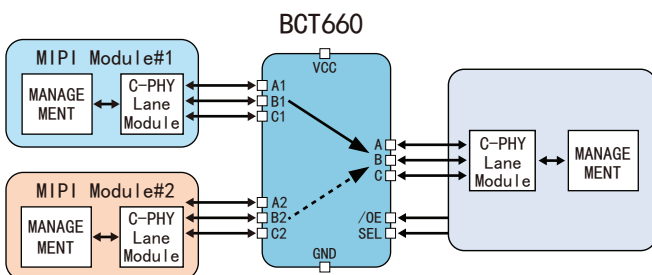

QFN2.8x2.0-18L

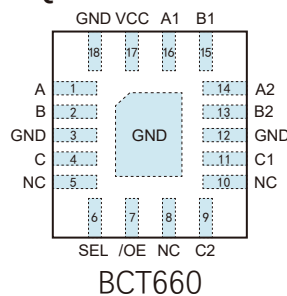

BCT660 - 2:1 MIPI C-PHY(5.7Gbps) 1-Data Lane Switch

Features

- Single Types: MIPI C-PHY
- Ron: 5.4 Ω Typical
- -3dB Bandwidth: 5.7GHz Typical
- I_o: 12uA Maximum
- Con: 0.8pF
- QFN2.8x2.0-18L Package

Audio Amplifier

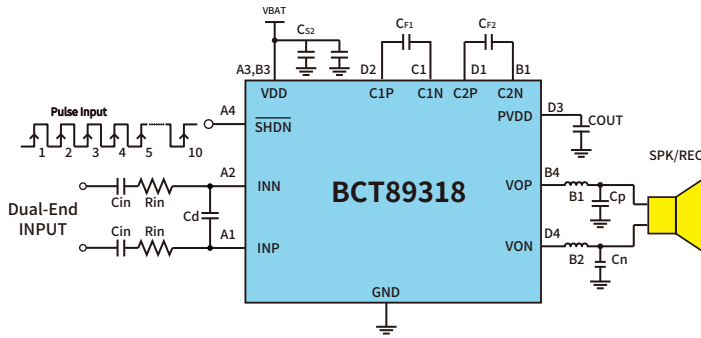

WCSP-14L

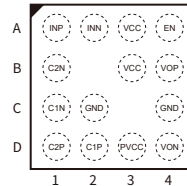

BCT89318



BCT89318-High efficiency, Low noise Class T Audio Amplifier

Features

- Class T Audio Amplifier
- Low noise: 43µV
- Selectable speaker-protection power level: 2.15W (Max Po-8Ω)
- ESD protection: ±6kV (HBM)
- Receiver: 3V/V, Vn=22µV, THD+N=0.01%
- Excellent pop-click suppression
- One wire pulse control
- Small 0.4mm pitch 1.58mm×1.63mm, WCSP-14L package

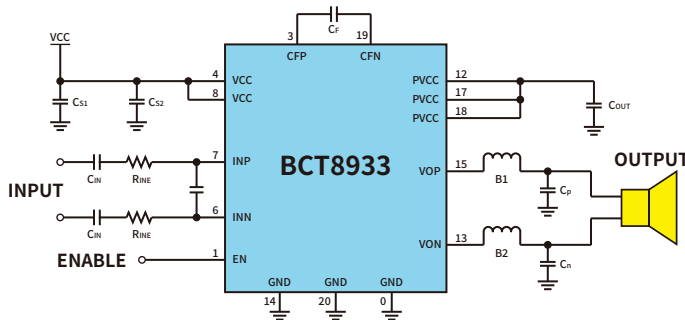

QFN3X3-20L

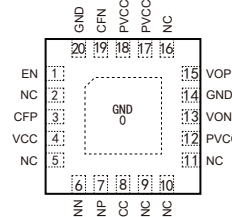

BCT8933



BCT8933-High Power, Low THD+N Class T Audio Amplifier

Features

- Digital Power Modulation audio algorithm
- 2.0W into 8Ω at 4.2V(10% THD+N)
- Ultra-Low THD+N: 0.03%
- 4 Mode selected by one-wire pulse
- High PSRR:-70dB
- Short Circuit and Thermal Protection
- ±8KV HBM ESD
- Small 3mm×3mm 20-Pin QFN Package

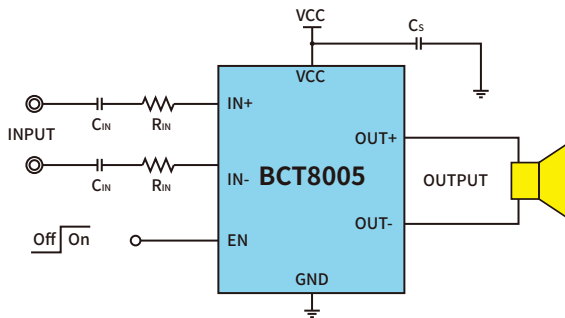

SOP8

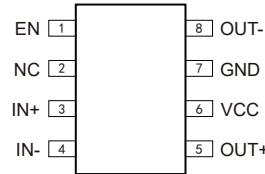

BCT8005



BCT8005-2.8W Mono Filter-less Class-D Audio Amplifier

Features

- Supply voltage range: 2.8V to 5.5V
- Support single-ended or differential analog input
- Low Quiescent Current
- Low Output Noise
- Low shut-down current
- Short power-on transient time
- Short-circuit protection
- Over-temperature protection
- Internal pull-low resistor on shut-down pins
- 1.67W/ch into 8Ω loudspeaker
- >3W/ch into 4Ω loudspeaker
- Loudspeaker power within 10% THD+N
- Loudspeaker efficiency 93% @ 8Ω, THD+N=10%, 85% @ 4Ω, THD+N=10%
- Integrated Feedback Resistor of 300kΩ

Charger

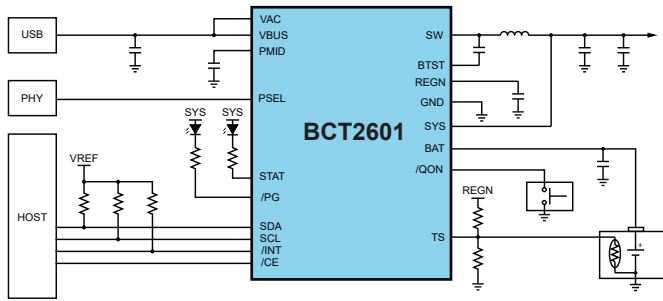

QFN4X4-24L

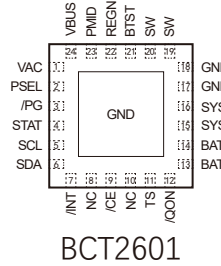

BCT2601 – 3A Single-cell Li-Ion Switching Charger with USB-OTG Boost

Features

- High Efficiency 1.5MHz Synchronous Buck Charger
- 20V Absolute Maximum Input Voltage Rating
- Boost Converter with up to 1.2A Output
- 3.9V to 13.5V Operating Input Voltage Range
- 91% Charge Efficiency at 2A from 5V Input
- Output Short Circuit Protection

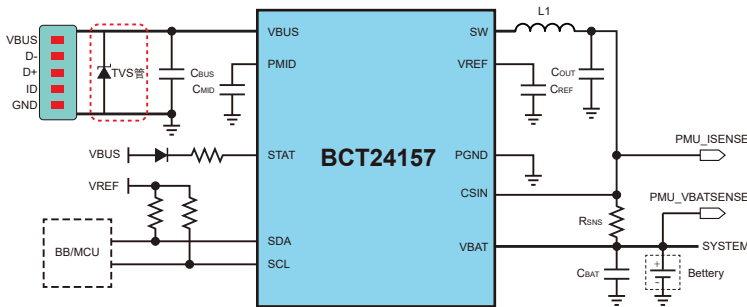

WLCSP-20L

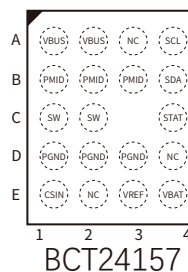

BCT24157 – 1.5A Single-cell Li-Ion Switching Charger with USB-OTG

Features

- Integrated Power FETs for Up to 1.5A Charge Current
- EOS 180V(Using PTVSHC3D12V)/300V(Using SMAJ12A)
- 24V Absolute Maximum Input Voltage Rating
- Boost Mode Operation for USB OTG: 5V/500mA
- 6.5V Maximum Operating Input Voltage
- Up to 90% Efficiency
- Excellent AIC LOOP Control

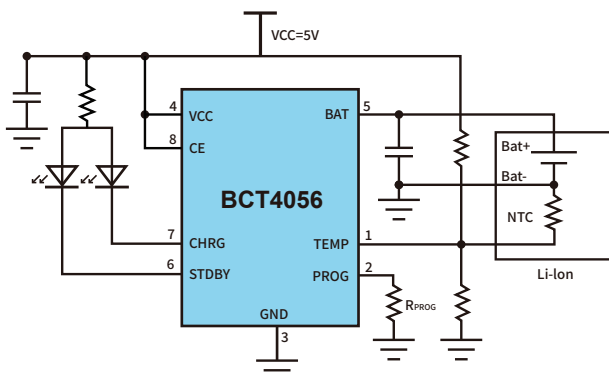

ESOP8

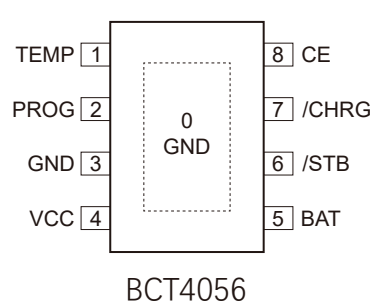

BCT4056 – 1.0A Single-Cell Li-Ion Linear

Features

- Integrated Power FETs for Up To 1.0A Charge Current
- Charge Termination Voltage: 4.2V(Typ.), 4.35V(Typ.)
- Standby Current: 55uA(Typ.)
- C/10 Charge Termination
- 6.5V Maximum Operating Input Voltage
- Programmable Charge Current
- Trickle Charge Voltage: 2.9V(Typ.)

Consumer Electronics Solution

Bluetooth Music Box Block Diagram

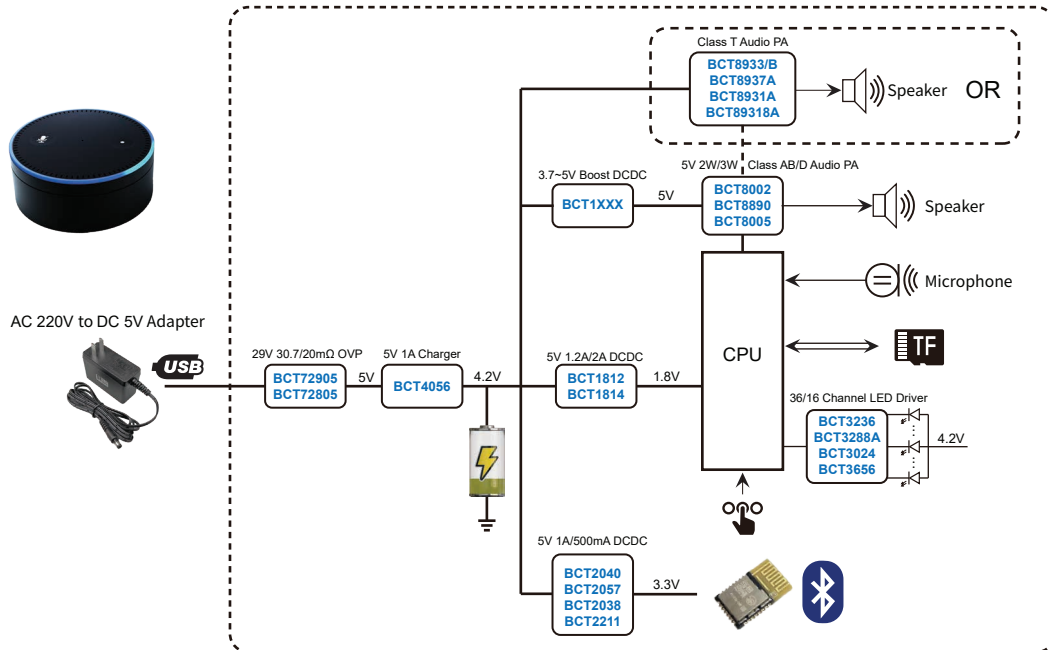

Set Top Box Block Diagram

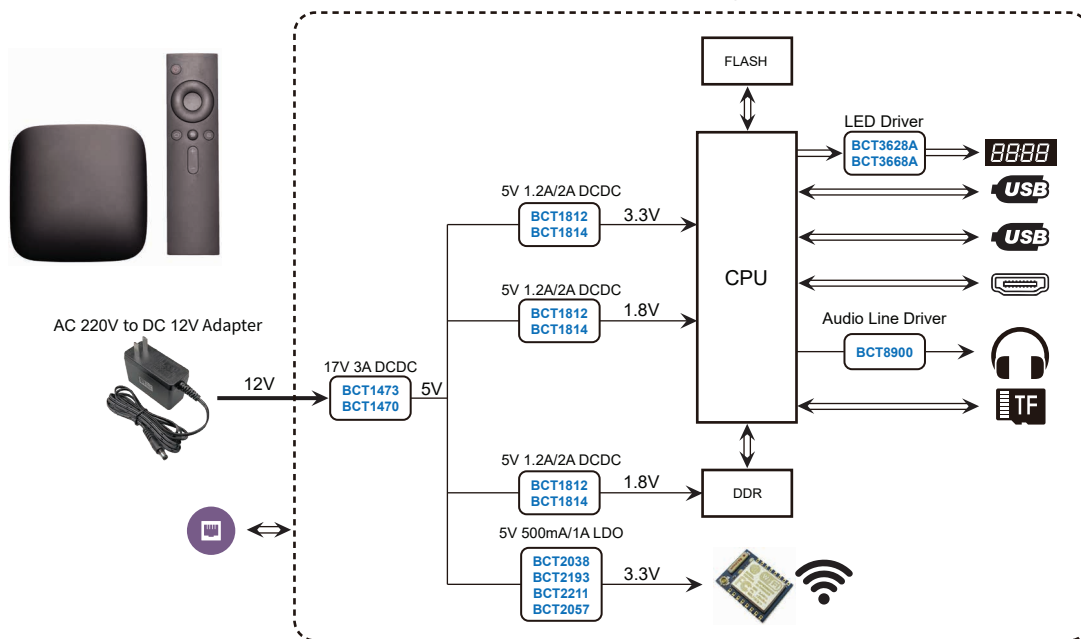

BCT1473

High-Efficiency, 17V, 3A Peak, 600kHz Synchronous, Step-Down Converter With COT Mode

BCT1814

5V 2000mA 1MHz Synchronous Step-Down Converter

BCT2038

5V 500mA Low Dropout Linear Regulators

BCT2057

5V 1000mA Low Dropout Linear Regulators

BCT3668A

70 Channels LED Driver With Slope Lighting Mode

BCT3024

24-Channel 256 Steps Constant-Current LED Driver

BCT8002/BCT8002H

Low-Cost, Mono 1.5W(RL=8Ω) Class AB Audio Power Amplifier

BCT8005/BCT8005L

Low-Cost, Mono 1.67W(RL=8Ω) Class D Audio Power Amplifier

BCT89318F/BCT89318T/BCT89318A

High Efficiency, Low Noise Class T Audio Amplifier

BCT72905

Over-Voltage Protection Load Switch

Funlight LED Driver

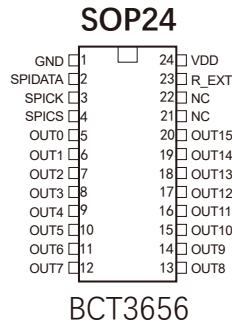
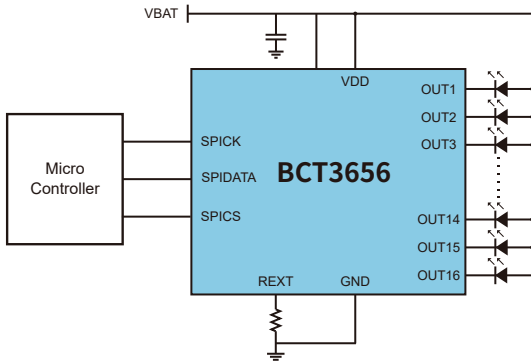

BCT3656 - 16 Channel 64 Steps Constant-Current LED Driver

Features

- 2.7V to 5.5V supply
- SPI interface, Internal reset register
- Modulate LED brightness with 64 levels
- Each channel can be controlled independently
- -40°C to +85°C temperature range
- SSOP24-1.0, SOP24

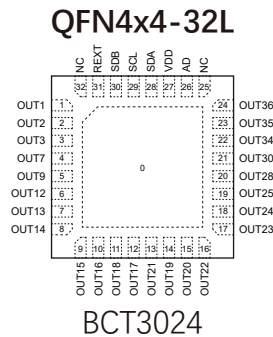
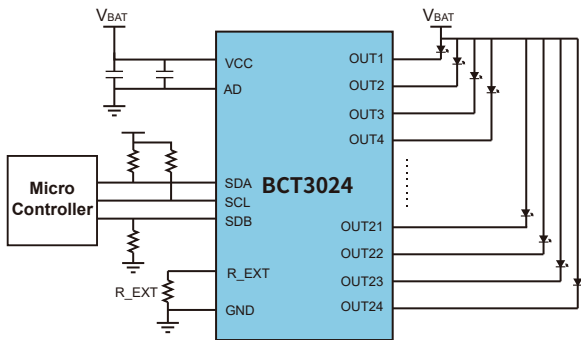

BCT3024 - 24 Channel 256 Steps Constant-Current LED Driver

Features

- 2.7V to 5.5V supply
- I2C interface, automatic address increment function
- Internal reset register
- Modulate LED brightness with 256 levels
- Each channel can be controlled independently
- Each channel can be scaled independently by 1, 1/2, 1/3 and 1/4
- -40°C to +85°C temperature range
- QFN4x4-32L (4mm × 4mm)

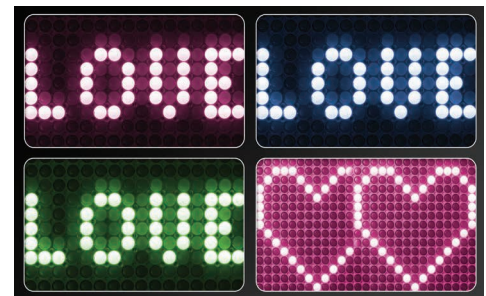
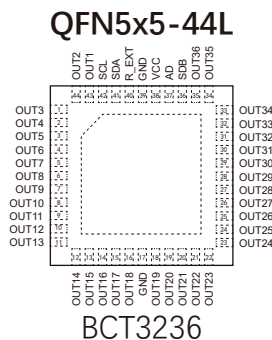
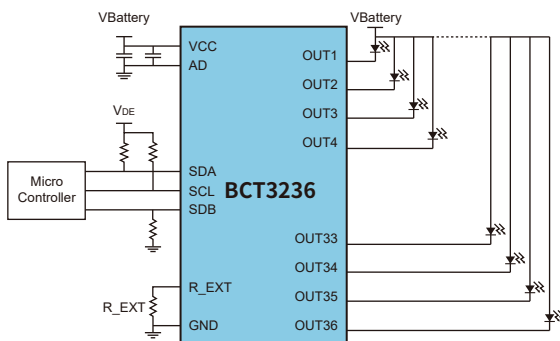

BCT3236 - 36 Channel 256 Steps Constant-Current LED Driver

Features

- 2.7V to 5.5V supply
- I2C interface, automatic address increment function
- Internal reset register
- Modulate LED brightness with 256 levels
- Each channel can be controlled independently
- Each channel can be scaled independently by 1, 1/2, 1/3 and 1/4
- -40°C to +85°C temperature range
- QFN5x5-44L (5mm × 5mm)

Security Camera Solution

Smart WiFi Pan&Tilt Camera Block Diagram

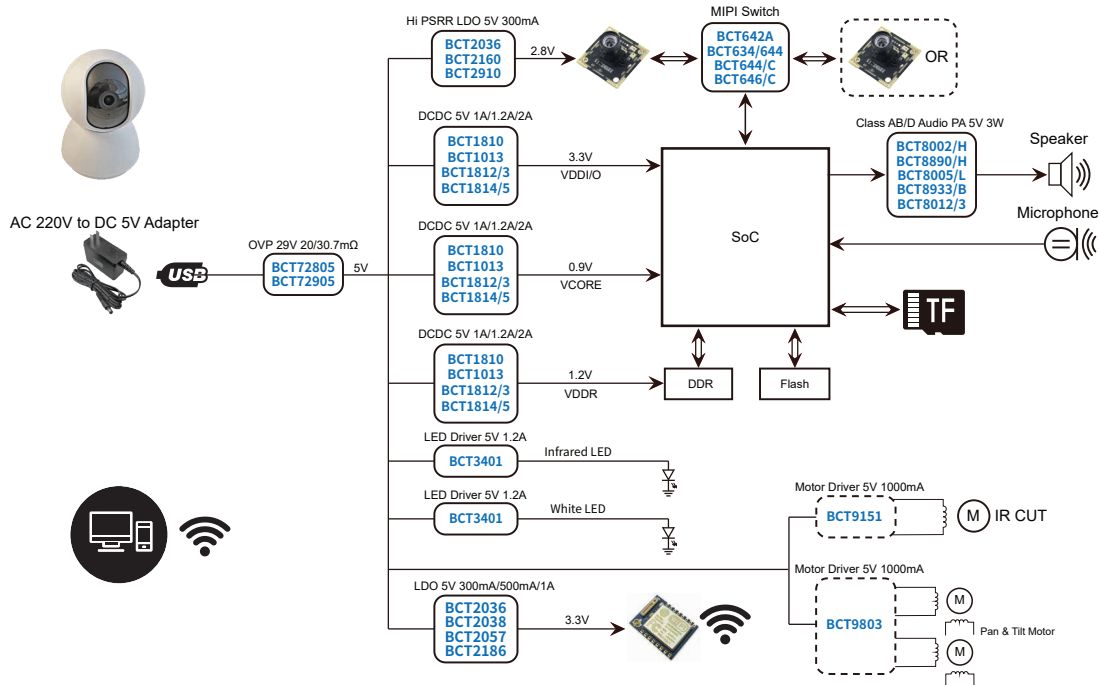

Network Camera Block Diagram

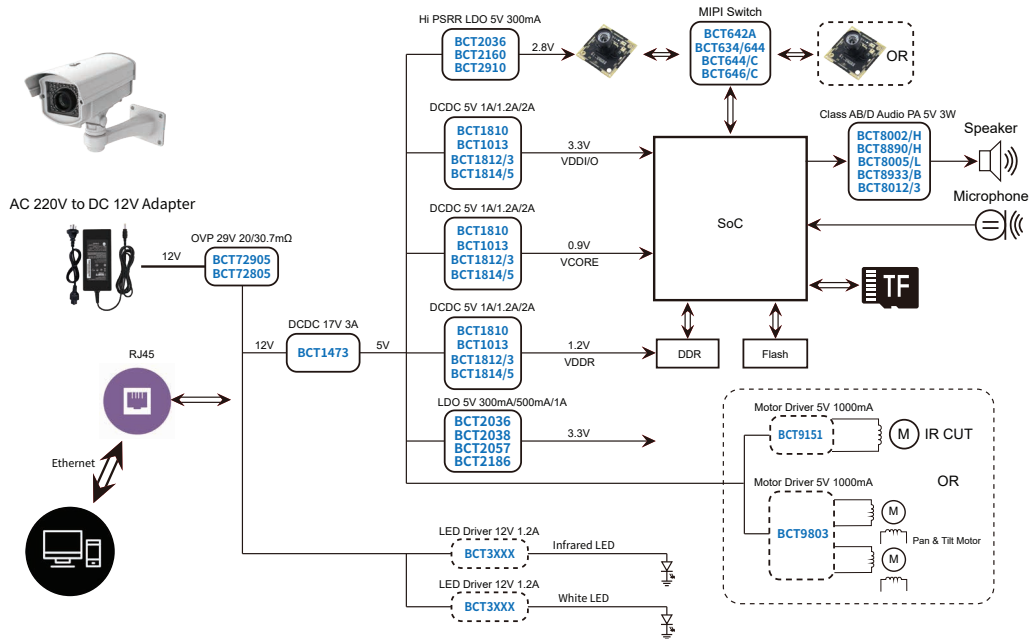

BCT1473

High-Efficiency, 17V, 3A Peak, 600kHz Synchronous, Step-Down Converter With COT Mode

BCT2036

5V 300mA Low Dropout Linear Regulators

BCT2038

5V 500mA Low Dropout Linear Regulators

BCT2057

5V 1000mA Low Dropout Linear Regulators

BCT3401

5V 1200mA DC-DC Converters-Backlight Driver

BCT8002/BCT8002H

Low-Cost, Mono 1.5W(RL=8Ω) Class AB Audio Power Amplifier

BCT8005/BCT8005L

Low-Cost, Mono 1.67W(RL=8Ω) Class D Audio Power Amplifier

BCT8933/BCT8933B

High Efficiency, Low Noise Class T Audio Amplifier

BCT8722

1MHz, 60uA, Rail to Rail I/O CMOS Operational Amplifier

BCT72905

Over-Voltage Protection Load Switch

DC-DC/LED Driver

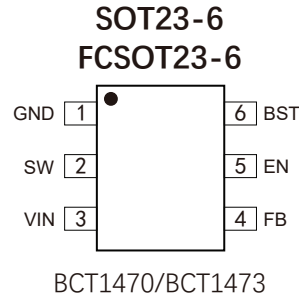
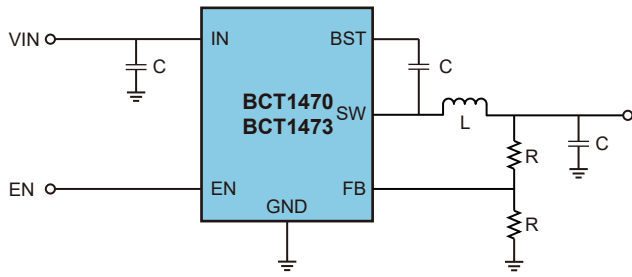

BCT1473 - 17V 3A Peak, 600kHz Synchronous, Step-Down Converter With ACOT Mode

Features

- Wide 4.7V to 17V Operating Input Range
- 90mΩ/50mΩ Internal NFET Efficiency: up to 94%
- ACOT Control with Fast Transient Response
- Pulse-Skip Mode
- Short-circuit Protection
- FCSOT23-5 Packages
- 600kHz Switching Frequency
- Cycle-by-Cycle Current Limit
- Internal Soft Start 1ms
- Startup from Pre-Biased Output Voltage
- Thermal Shutdown

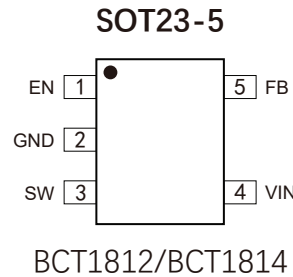
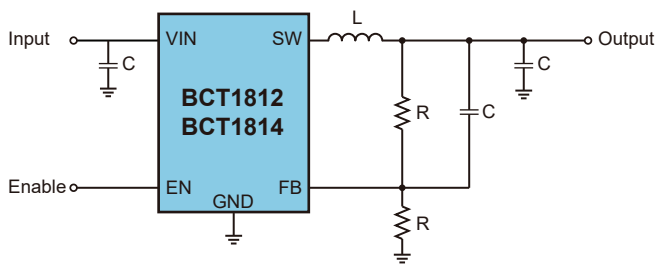

BCT1814 - 5V 2A 1MHz Synchronous Step-Down Converter

Features

- 2.7V~5.5V Input Voltage Range
- 2A Output Current
- 1MHz Switching Frequency Minimizes the External Components
- 100% Duty Cycle in Dropout Operation
- Output Voltage as Low as 0.6V
- No Schottky Diode Required, Internal soft-start
- Output short protection
- Output Auto-Discharge When EN Low
- Thermal protection
- SOT23-5 Packages

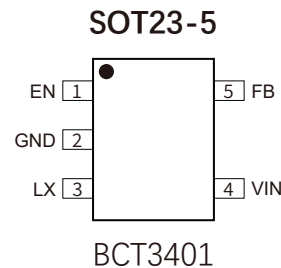
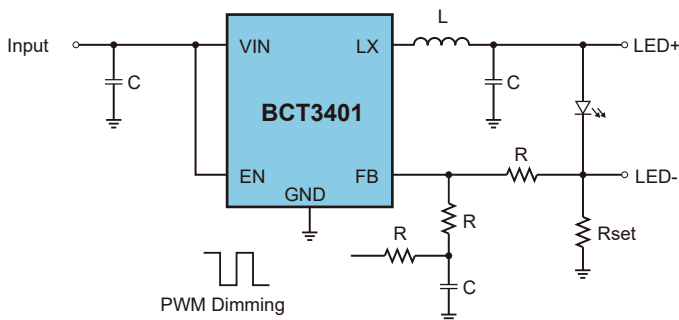

BCT3401 - 5V 1.2A DC-DC Converters-Backlight Driver

Features

- 2.5V~5.5V Input Voltage Range
- 1.2A Output Current
- 1.5MHz Switching Frequency
- Shutdown Current : <1μA
- Up to 92% efficiency
- 100% Duty Cycle in Dropout Operation
- Internal soft-start
- PWM dimming
- Output short protection, Thermal Protection
- SOT23-5 Packages

Home Appliance Solution

Blender Block Diagram

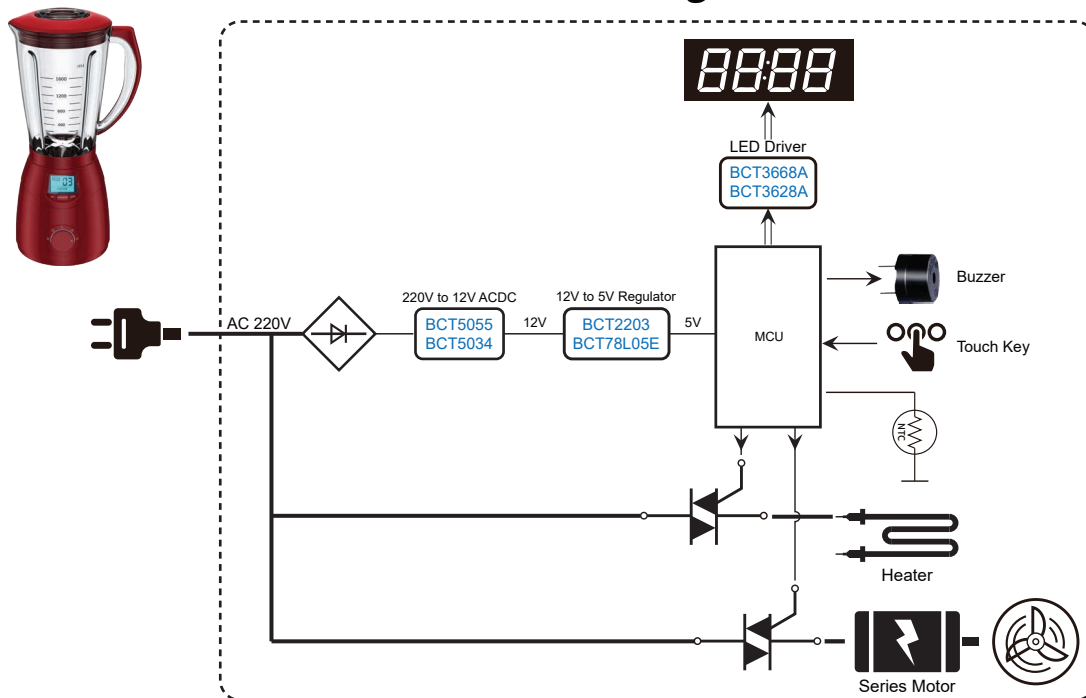

Electric Kettle Block Diagram

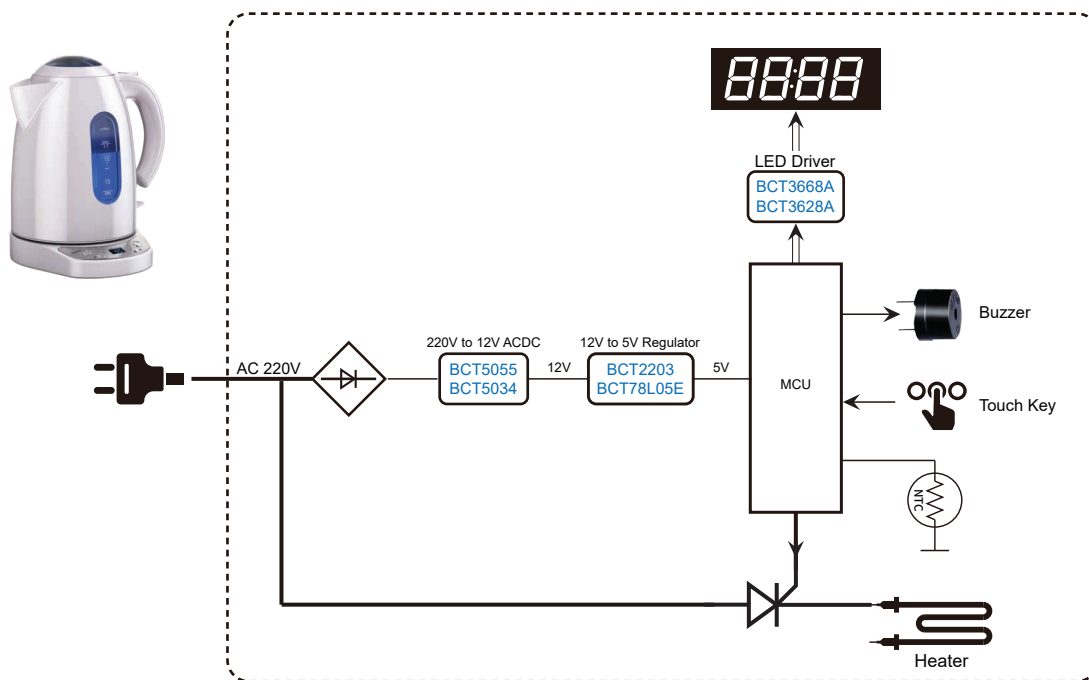

BCT5034

AC 220V to DC 12V 200mA Non-isolation Converter

BCT78L05E

5V 150mA High Voltage Regulator

BCT2203

150mA High Voltage Regulator

BCT8002/BCT8002H

Low-Cost, Mono 1.5W(RL=8Ω) Class AB Audio Power Amplifier

BCT3668A

70 Channels LED Driver With Slope Lighting Mode

BCT3628A

70 Channels LED Driver With Slope Lighting Mode

BCT3024

24-Channel 256 Steps Constant-Current LED Driver

BCT3656

16-Channel 64 Steps Constant-Current LED Driver

AC-DC/Display Driver/Audio PA

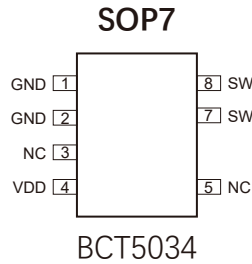
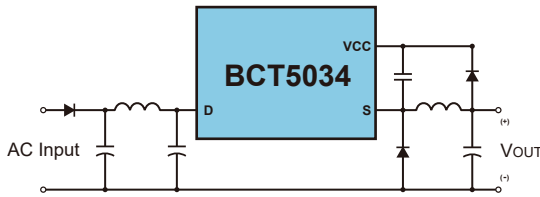

BCT5034 - AC 220V to DC 12V 200mA Non-isolation Converter

Features

- VCC Inner Loop Feedback Control
- Integrated with 700V Power MOSFET
- Built-in Ultra High Voltage Startup Circuit
- Maximum Switching Frequency at 65 kHz
- Frequency Swapping for EMI improvement
- Green Mode Control for Power Saving
- Internal Thermal Shutdown

SOP24

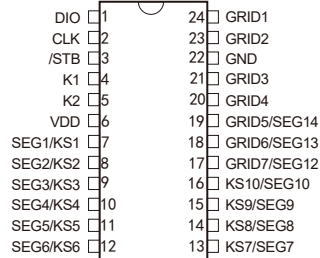

BCT3668/BCT3668A

SOP28

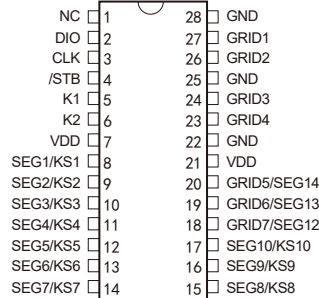

BCT3628/BCT3628A



BCT3668A/3628A - 70 Channels LED Driver With Slope Lighting Mode

Features

- Wide operation Voltage: 3.0V to 5.5V
- Serial Interface
- 8-Step/256-Step Dimming Circuitry
- Built in OSC generator
- Pulse Segment Current: 50 mA type
- Key scanning: 10 × 2 matrix
- Operation Temperature: -40 to 85°C

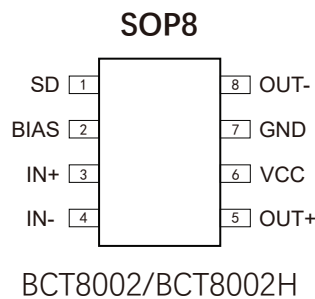
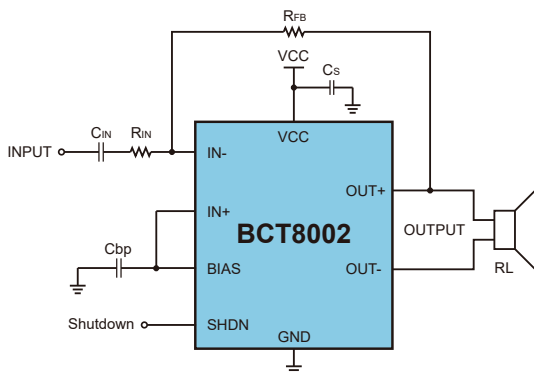

BCT8002 - Low-Cost, Mono 1.5W(RL=8Ω) Class AB Audio Power Amplifier

Features

- 2.5V to 5.5V Single-Supply Operation
- PO at 10% THD+N, f=1KHz, VDD=5V
RL=8 Ω 1.5W(Typ.)
RL=4 Ω 2.2W(Typ.)
- Less than 1uA Low-Power Shutdown Mode
- 64dB PSRR at 1KHz
- Temperature Range: -40°C to 85°C
- No Audible Clicks or Pops at Power-Up/Down
- Available in SOP8 package

LCD TV

43" Smart TV MainBoard (CPU+AC/DC+Backlight 3in1) Block Diagram

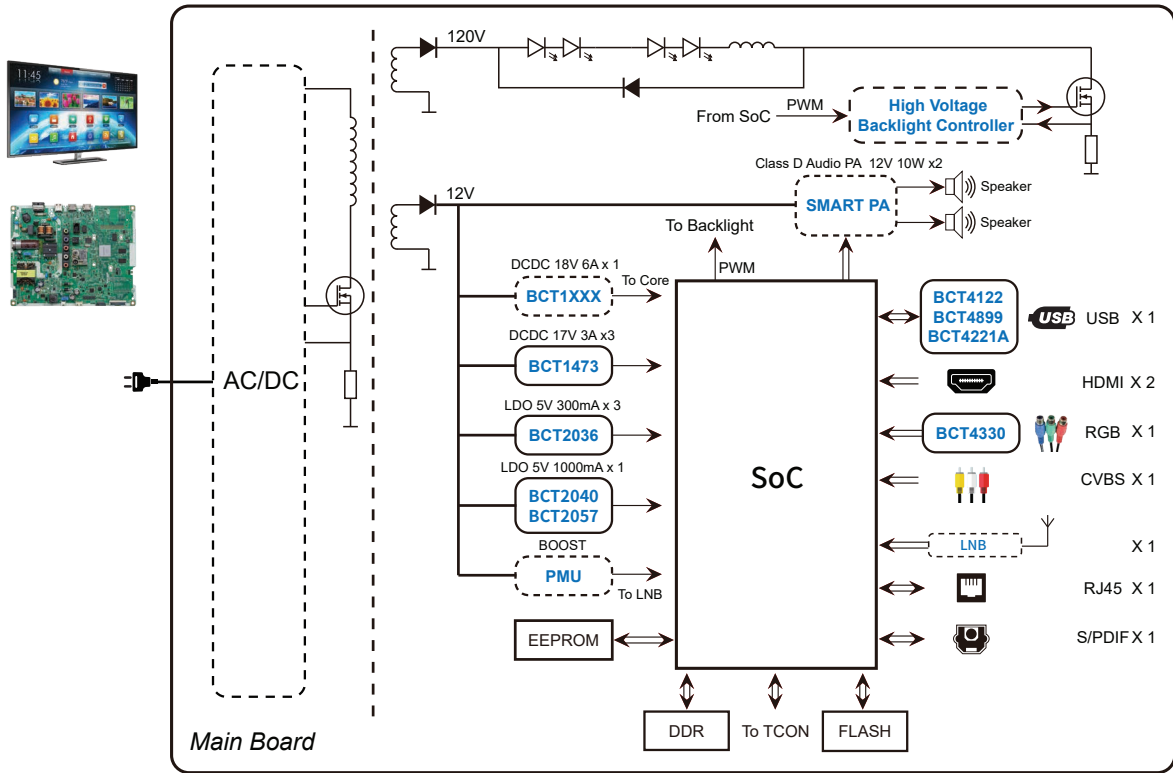

50" Smart TV MainBoard (CPU+TCON 2in1) Block Diagram

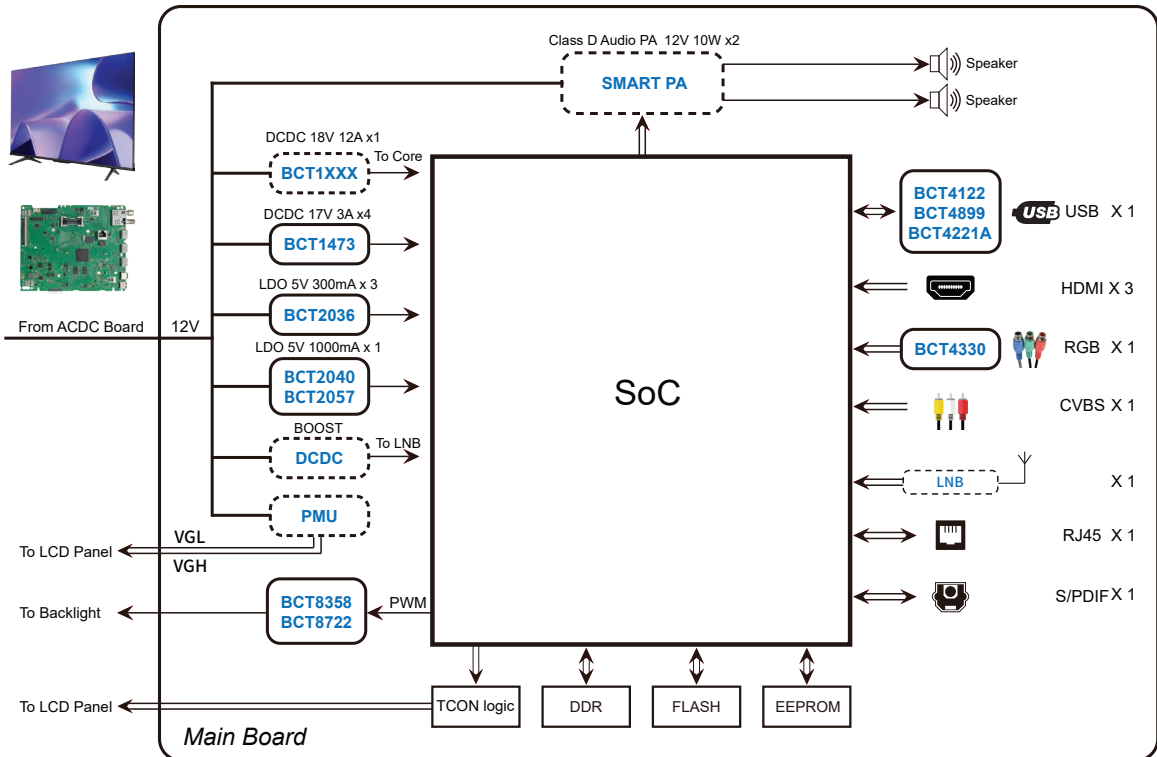

BCT1473
17V 3A 600KHz Synchronous Buck Converter

BCT8358
2 Channel RRIO 1MHz CMOS Amplifier

BCT2036
300mA Low IQ Low Dropout Regulators

BCT2040
1000mA Low Dropout Regulators

CONTACT US

联系我们

Shanghai

上海总部

AD: Floor 17, Building H, Weijing Center, No. 2337, Gudai Road, Minhang District, Shanghai, China

上海市闵行区顾戴路2337号维璟中心H幢17层

P.C.: 201199

Tel: 021 - 64472383 64472385

MB: 13391139563

Shenzhen

深圳

AD: Room 1101, Floor 11, Dingxin Building East Block, No. 6008, Xili Liuxian Avenue, Nanshan District, Shenzhen, China

深圳市南山区西丽留仙大道6008号鼎新大厦东座11层1101室

P.C.: 518055

Tel: 13386121579

Hangzhou

杭州

AD: Room 1801~1807, Floor 18, Huaye Building, No. 511, Jianye Road, Binjiang District, Hangzhou, China

杭州市滨江区建业路511号华业大厦18层1801-1807室

P.C.: 310052

Tel: 13956026978

Hong Kong

香港

AD: 19H Maxground Plaza, No.3 Tai Yau Street, San Po Kong, Kowloon, Hong Kong, China

Tel: +852 - 25832396

Fax: +852 - 30119876



www.broadchip.com